PCI Express™®

Card Electromechanical
Specification

Revision ~~1.1~~ 2.0

~~March 28, 2005~~

April 11, 2007



Revision	Revision History	Date
1.0	Initial release.	7/22/ <u>2002</u>
1.0a	Incorporated WG Errata C1-C7 and E1.	4/15/ <u>2003</u>
1.1	Incorporated approved Errata and ECNs.	03/28/ <u>2005</u>
<u>2.0</u>	<u>Added support for 5 GT/s data rate.</u>	<u>4/11/2007</u>

[PCI-SIG](#)[®] disclaims all warranties and liability for the use of this document and the information contained herein and assumes no responsibility for any errors that may appear in this document, nor does PCI-SIG make a commitment to update the information contained herein.

Contact the PCI-SIG office to obtain the latest revision of the specification.

Questions regarding this specification or membership in PCI-SIG may be forwarded to:

Membership Services

www.pcisig.com

E-mail: administration@pcisig.com

Phone: - ~~503-291-2569~~
619-0569

Fax: - ~~503-297-1090~~ 644-6708

Technical Support

techsupp@pcisig.com

DISCLAIMER

This PCI Express Card Electromechanical Specification is provided “as is” with no warranties whatsoever, including any warranty of merchantability, noninfringement, fitness for any particular purpose, or any warranty otherwise arising out of any proposal, specification, or sample. PCI-SIG disclaims all liability for infringement of proprietary rights, relating to use of information in this specification. No license, express or implied, by estoppel or otherwise, to any intellectual property rights is granted herein.

PCI, ~~PCI Express is a trademark~~, PCIe, and PCI-SIG are trademarks or registered trademarks of PCI-SIG.

All other product names are trademarks, registered trademarks, or service marks of their respective owners.

Contents

1. INTRODUCTION.....	9
1.1. TERMS AND DEFINITIONS	9
1.2. REFERENCE DOCUMENTS	10
1.3. SPECIFICATION CONTENTS	11
1.4. OBJECTIVES.....	11
1.5. ELECTRICAL OVERVIEW	12
1.6. MECHANICAL OVERVIEW	13
2. AUXILIARY SIGNALS.....	15
2.1. REFERENCE CLOCK.....	16
2.1.1. <i>Low Voltage Swing, Differential Clocks</i>	16
2.1.2. <i>Spread Spectrum Clocking (SSC)</i>	17
2.1.3. <i>REFCLK AC Specifications</i>	18
2.1.4. <i>REFCLK Phase Jitter Specification For 2.5 GT/s Signaling Support</i>	21
2.1.5. <i>REFCLK Phase Jitter Specification For 5 GT/s Signaling Support</i>	22
2.2. PERST# SIGNAL	22
2.2.1. <i>Initial Power-Up (G3 to S0)</i>	23
2.2.2. <i>Power Management States (S0 to S3/S4 to S0)</i>	25
2.2.3. <i>Power Down</i>	27
2.3. WAKE# SIGNAL	29
2.4. SMBUS (OPTIONAL).....	32
2.4.1. <i>Capacitive Load of High-power SMBus Lines</i>	32
2.4.2. <i>Minimum Current Sinking Requirements for SMBus Devices</i>	33
2.4.3. <i>SMBus “Back Powering” Considerations</i>	33
2.4.4. <i>Power-on Reset</i>	33
2.5. JTAG PINS (OPTIONAL).....	34
2.6. AUXILIARY SIGNAL PARAMETRIC SPECIFICATIONS	35
2.6.1. <i>DC Specifications</i>	35
2.6.2. <i>AC Specifications</i>	36
3. HOT INSERTION AND REMOVAL.....	37
3.1. SCOPE	37
3.2. PRESENCE DETECT	37
4. ELECTRICAL REQUIREMENTS	39
4.1. POWER SUPPLY REQUIREMENTS	39
4.2. POWER CONSUMPTION	40
4.3. POWER SUPPLY SEQUENCING.....	41
4.4. POWER SUPPLY DECOUPLING.....	42
4.5. ELECTRICAL TOPOLOGIES AND LINK DEFINITIONS	42
4.5.1. <i>Topologies</i>	42
4.5.2. <i>Link Definition</i>	44
4.6. ELECTRICAL BUDGETS	45
4.6.1. <i>AC Coupling Capacitors</i>	46
4.6.2. <i>Insertion Loss Values (Voltage Transfer Function)</i>	46
4.6.3. <i>Jitter Values</i>	48
4.6.4. <i>Crosstalk</i>	50

4.6.5.	<i>Lane-to-Lane Skew</i>	51
4.6.6.	<i>Equalization</i>	51
4.6.7.	<i>Skew within the Differential Pair</i>	51
4.6.8.	<i>Differential Data Trace Impedance</i>	52
4.6.9.	<i>Differential Data Trace Propagation Delay</i>	52
4.7.	EYE DIAGRAMS AT THE ADD-IN CARD INTERFACE	53
4.7.1.	<i>Add-in Card Transmitter Path Compliance Eye Diagram at 2.5 GT/s</i>	53
	<i>Add-in Card Transmitter Path</i>	54
4.7.2.	<i>Compliance Eye Diagrams at 5 GT/s</i>	54
4.7.3.	<i>Add-in Card Minimum Receiver Path Sensitivity Requirements at 2.5 GT/s</i>	57
4.7.4.	<i>Add-in Card Minimum Receiver Path Sensitivity Requirements at 5 GT/s</i>	59
4.7.5.	<i>System Board Transmitter Path Compliance Eye Diagram at 2.5 GT/s</i>	60
4.7.6.	<i>System Board Transmitter Path Compliance Eye Diagram at 5 GT/s</i>	61
4.7.7.	<i>System Board Minimum Receiver Path Sensitivity Requirements at 2.5 GT/s</i>	65
4.7.8.	<i>System Board Minimum Receiver Path Sensitivity Requirements at 5 GT/s</i>	66
5.	CONNECTOR SPECIFICATION	69
5.1.	CONNECTOR PINOUT	69
5.2.	CONNECTOR INTERFACE DEFINITIONS	73
5.3.	SIGNAL INTEGRITY REQUIREMENTS AND TEST PROCEDURES	81
5.3.1.	<i>Signal Integrity Requirements</i>	81
5.3.2.	<i>Signal Integrity Requirements and Test Procedures for 2.5 GT/s Support</i>	81
5.3.3.	<i>Signal Integrity Requirements and Test Procedures for 5 GT/s Support</i>	84
	5.3.3.1 <i>Test Fixture Requirements</i>	86
5.4.	CONNECTOR ENVIRONMENTAL AND OTHER REQUIREMENTS	86
5.4.1.	<i>Environmental Requirements</i>	86
5.4.2.	<i>Mechanical Requirements</i>	88
5.4.3.	<i>Current Rating Requirement</i>	89
5.4.4.	<i>Additional Considerations</i>	89
6.	ADD-IN CARD FORM FACTORS AND IMPLEMENTATION	91
6.1.	ADD-IN CARD FORM FACTORS.....	91
6.2.	CONNECTOR AND ADD-IN CARD LOCATIONS	104
6.3.	CARD INTEROPERABILITY	110
A.	INSERTION LOSS VALUES (VOLTAGE TRANSFER FUNCTION) (INFORMATIONAL ONLY)	113
	ACKNOWLEDGEMENTS	117

Figures

FIGURE 1-1: VERTICAL EDGE-CARD CONNECTOR	13
FIGURE 1-2: EXAMPLE SERVER I/O BOARD WITH PCI EXPRESS SLOTS ON A RISER	13
FIGURE 2-1: DIFFERENTIAL REFCLK WAVEFORM	16
FIGURE 2-2: EXAMPLE CURRENT MODE REFERENCE CLOCK SOURCE TERMINATION	17
FIGURE 2-3: SINGLE-ENDED MEASUREMENT POINTS FOR ABSOLUTE CROSS POINT AND SWING	19
FIGURE 2-4: SINGLE-ENDED MEASUREMENT POINTS FOR DELTA CROSS POINT	20
FIGURE 2-5: SINGLE-ENDED MEASUREMENT POINTS FOR RISE AND FALL TIME MATCHING	20
FIGURE 2-6: DIFFERENTIAL MEASUREMENT POINTS FOR DUTY CYCLE AND PERIOD	20
FIGURE 2-7: DIFFERENTIAL MEASUREMENT POINTS FOR RISE AND FALL TIME	20
FIGURE 2-8: DIFFERENTIAL MEASUREMENT POINTS FOR RINGBACK	21
FIGURE 2-9: REFERENCE CLOCK SYSTEM MEASUREMENT POINT AND LOADING	21
FIGURE 2-10: POWER UP	24
FIGURE 2-11: POWER MANAGEMENT STATES	26
FIGURE 2-12: OUT-OF-TOLERANCE THRESHOLD WINDOWS	27
FIGURE 2-13: POWER DOWN	28
FIGURE 2-14: WAKE# RISE AND FALL TIME MEASUREMENT POINTS	36
FIGURE 3-1: PRESENCE DETECT IN A HOT-PLUG ENVIRONMENT	38
FIGURE 4-1: PCI EXPRESS ON THE SYSTEM BOARD	43
FIGURE 4-2: PCI EXPRESS CONNECTOR ON SYSTEM BOARD WITH AN ADD-IN CARD	43
FIGURE 4-3: PCI EXPRESS CONNECTOR ON A RISER CARD WITH AN ADD-IN CARD	44
FIGURE 4-4: LINK DEFINITION FOR TWO COMPONENTS	45
FIGURE 4-5: JITTER BUDGET	48
FIGURE 4-6: ADD-IN CARD TRANSMITTER PATH COMPLIANCE EYE DIAGRAM	54
FIGURE 4-7: ADD-IN CARD TRANSMITTER PATH COMPLIANCE EYE DIAGRAM	57
FIGURE 4-8: REPRESENTATIVE COMPOSITE EYE DIAGRAM FOR ADD-IN CARD RECEIVER PATH COMPLIANCE	58
FIGURE 4-9: REPRESENTATIVE COMPOSITE EYE DIAGRAM FOR ADD-IN CARD RECEIVER PATH COMPLIANCE	60
FIGURE 4-10: SYSTEM BOARD TRANSMITTER PATH COMPOSITE COMPLIANCE EYE DIAGRAM	61
FIGURE 4-11	62
: TWO PORT MEASUREMENT FUNCTIONAL BLOCK DIAGRAM	63
FIGURE 4-12: SYSTEM BOARD TRANSMITTER PATH COMPOSITE COMPLIANCE EYE DIAGRAM	65
FIGURE 4-13: REPRESENTATIVE COMPOSITE EYE DIAGRAM FOR SYSTEM BOARD RECEIVER PATH COMPLIANCE	67
FIGURE 5-1: CONNECTOR FORM FACTOR	75
FIGURE 5-2: RECOMMENDED FOOTPRINT	77
FIGURE 5-3: ADD-IN CARD EDGE-FINGER DIMENSIONS	79
FIGURE 5-4: ILLUSTRATION OF ADJACENT PAIRS	84
FIGURE 5-5: CONTACT RESISTANCE MEASUREMENT POINTS	87
FIGURE 6-1: STANDARD HEIGHT PCI EXPRESS ADD-IN CARD WITHOUT THE I/O BRACKET	92
FIGURE 6-2: STANDARD HEIGHT PCI EXPRESS ADD-IN CARD WITH THE I/O BRACKET AND CARD RETAINER	93
FIGURE 6-3: ADDITIONAL FEATURE AND KEEPOUTS ON THE X16 GRAPHICS CARD	94

FIGURE 6-4: STANDARD ADD-IN CARD I/O BRACKET 95

FIGURE 6-5: BRACKET DESIGN WITH THE MOUNTING TABS MOUNTED ON THE
PRIMARY SIDE OF THE ADD-IN CARD 96

FIGURE 6-6: ADD-IN CARD RETAINER 97

FIGURE 6-7: LOW PROFILE PCI EXPRESS ADD-IN CARD WITHOUT THE I/O BRACKET 100

FIGURE 6-8: LOW PROFILE PCI EXPRESS ADD-IN CARD WITH THE I/O BRACKET 101

FIGURE 6-9: LOW PROFILE I/O BRACKET 102

FIGURE 6-10: FULL HEIGHT I/O BRACKET FOR LOW PROFILE CARDS 103

FIGURE 6-11: EXAMPLE OF A PC SYSTEM IN MICROATX FORM FACTOR 104

FIGURE 6-12: INTRODUCTION OF A PCI EXPRESS CONNECTOR IN A MICROATX
SYSTEM 105

FIGURE 6-13: MORE PCI EXPRESS CONNECTORS ARE INTRODUCED ON A MICROATX
SYSTEM BOARD 106

FIGURE 6-14: PCI EXPRESS CONNECTOR LOCATION IN A MICROATX SYSTEM WITH ONE
PCI EXPRESS CONNECTOR 108

FIGURE 6-15: PCI EXPRESS CONNECTOR LOCATION IN A MICROATX SYSTEM WITH
TWO PCI EXPRESS CONNECTORS 109

FIGURE 6-16: CARD ASSEMBLED IN CONNECTOR 110

FIGURE A-1: EXAMPLE INTERCONNECT TERMINATED AT THE CONNECTOR
INTERFACE 113

FIGURE A-2: INSERTION LOSS BUDGETS 114

Tables

TABLE 2-1: REFCLK DC SPECIFICATIONS AND AC TIMING REQUIREMENTS	18
TABLE 2-2: MAXIMUM ALLOWED PHASE JITTER WHEN APPLIED TO FIXED FILTER CHARACTERISTIC	22
TABLE 2-3: AUXILIARY SIGNAL DC SPECIFICATIONS - PERST#, WAKE#, AND SMBUS	35
TABLE 2-4: POWER SEQUENCING AND RESET SIGNAL TIMINGS	36
TABLE 4-1: POWER SUPPLY RAIL REQUIREMENTS	39
TABLE 4-2: ADD-IN CARD POWER DISSIPATION	40
TABLE 4-3: TOTAL SYSTEM JITTER BUDGET FOR 2.5 GT/S SIGNALING	49
TABLE 4-4: ALLOCATION OF INTERCONNECT JITTER BUDGET FOR 2.5 GT/S SIGNALING	49
TABLE 4-5: TOTAL SYSTEM JITTER BUDGET FOR 5 GT/S SIGNALING	50
TABLE 4-6: ALLOWABLE INTERCONNECT LANE-TO-LANE SKEW	51
TABLE 4-7: ADD-IN CARD TRANSMITTER PATH COMPLIANCE EYE REQUIREMENTS AT 2.5 GT/S	53
TABLE 4-8: ADD-IN CARD TRANSMITTER PATH COMPLIANCE EYE REQUIREMENTS AT 5 GT/S AND 3.5 DB DE-EMPHASIS	54
TABLE 4-9: ADD-IN CARD JITTER REQUIREMENTS FOR 5 GT/S SIGNALING AT 3.5 DB DE-EMPHASIS	55
TABLE 4-10: ADD-IN CARD TRANSMITTER PATH COMPLIANCE EYE REQUIREMENTS AT 5 GT/S AT 6.0 DB DE-EMPHASIS	55
TABLE 4-11: ADD-IN CARD JITTER REQUIREMENTS FOR 5 GT/S SIGNALING AT 6.0 DB DE-EMPHASIS	57
TABLE 4-12: ADD-IN CARD MINIMUM RECEIVER PATH SENSITIVITY REQUIREMENTS AT 2.5 GT/S	57
TABLE 4-13: ADD-IN CARD MINIMUM RECEIVER PATH SENSITIVITY REQUIREMENTS AT 5 GT/S	59
TABLE 4-14: SYSTEM BOARD TRANSMITTER PATH COMPLIANCE EYE REQUIREMENTS AT 2.5 GT/S	60
TABLE 4-15: SYSTEM BOARD TRANSMITTER PATH COMPLIANCE EYE REQUIREMENTS AT 5 GT/S	64
TABLE 4-16: SYSTEM BOARD JITTER REQUIREMENTS FOR 5 GT/S SIGNALING	65
TABLE 4-17: SYSTEM BOARD MINIMUM RECEIVER PATH SENSITIVITY REQUIREMENTS AT 2.5 GT/S	65
TABLE 4-18: SYSTEM BOARD MINIMUM RECEIVER PATH SENSITIVITY REQUIREMENTS AT 5 GT/S FOR A LINK THAT OPERATES WITH 3.5 DB DE-EMPHASIS	66
TABLE 4-19: SYSTEM BOARD MINIMUM RECEIVER PATH SENSITIVITY REQUIREMENTS AT 5 GT/S FOR A LINK THAT OPERATES WITH 6.0 DB DE-EMPHASIS	67
TABLE 5-1: PCI EXPRESS CONNECTORS PINOUT	69
TABLE 5-2: SIGNAL INTEGRITY REQUIREMENTS AND TEST PROCEDURES FOR 2.5 GT/S SUPPORT	82
TABLE 5-3: SIGNAL INTEGRITY REQUIREMENTS AND TEST PROCEDURES FOR 5 GT/S SUPPORT	85
TABLE 5-4: TEST DURATIONS	87
TABLE 5-5: MECHANICAL TEST PROCEDURES AND REQUIREMENTS	88
TABLE 5-6: END OF LIFE CURRENT RATING TEST SEQUENCE	89

TABLE 5-7: ADDITIONAL REQUIREMENTS	89
TABLE 6-1: ADD-IN CARD SIZES	91
TABLE 6-2: CARD INTEROPERABILITY	110
TABLE A-1: ALLOCATION OF INTERCONNECT PATH INSERTION LOSS BUDGET FOR 2.5 GT/S SIGNALING.....	114

1

1. Introduction

This specification is a companion for the *PCI Express Base Specification, Revision ~~1.1~~2.0*. Its primary focus is the implementation of an evolutionary strategy with the current PCI™ desktop/server mechanical and electrical specifications. The discussions are confined to ATX or ATX-based form factors. Other form factors, such as PCI Express® Mini Card are covered in other separate specifications.

1.1. Terms and Definitions

Add add-in card	A card that is plugged into a connector and mounted in a chassis slot.
ATX	A system board form factor. Refer to the <i>ATX Specification, Revision. 2.2</i> .
ATX-based form factor	Refers to the form factor that does not exactly conform to the ATX specification, but uses the key features of the ATX, such as the slot spacing, I/O panel definition, etc.
Auxiliary signals	Signals not required by the PCI Express architecture but necessary for certain desired functions or system implementation, for example, the SMBus signals.
Basic bandwidth	Contains one PCI Express Lane
x1, x2 , x4, x8, x12 , x16	x1 refers to one PCI Express Lane of basic bandwidth; x4 refers to a collection of four PCI Express Lanes; etc.
<u>Card Interoperability</u>	<u>Ability to plug a PCI Express card into different Link connectors and the system works, for example, plugging a PCI Express x1 I/O card into a x16 graphics slot.</u>
Down-plugging	Plugging a larger Link card into a smaller Link connector; for example, plugging a x4 card into a x1 connector
Down-shifting	Plugging a PCI Express card into a connector that is not fully routed for all of the PCI Express Lanes; for example, plugging a x4 card into a x8 capable connector with only four Lanes being routed
Evolutionary strategy	A strategy to develop the PCI Express connector and card form factors within today's chassis and system board form factor infrastructure constraints.
High bandwidth	Supports larger number of PCI Express Lanes, such as a x16 card or connector.

	Hot-Plug	Insertion and/or removal of a card into an active backplane or system board as defined in <i>PCI Standard Hot-Plug Controller and Subsystem Specification, Revision 1.0</i> . No special card support is required.
5	Hot swap	Insertion and/or removal of a card into a passive backplane. The card must satisfy specific requirements to support Hot swap.
	Interoperability	Ability to plug a PCI Express card into different Link connectors and the system works, for example, plugging a x1 PCI Express I/O card into a x16 graphics slot.
	Link	A collection of one or more PCI Express Lanes
10	Low profile card	An add-in card whose height is no more than 68.90 mm (2.731 inches)
	microATX	An ATX-based system board form factor. Refer to the <i>microATX Motherboard Interface Specification, Revision 1.2</i> .
	PCI Express Mini Card	PCI Express for mobile form factor, similar to Mini PCI
15	PCI Express Lane	One PCI Express Lane contains two differential lines for Transmitter and two differential lines for Receiver. A by-N Link is composed of N Lanes.
	<u>Receiver path</u>	<u>The path from the connector to the receiver for a differential data pair (system) or the edge finger to the receiver (add-in card).</u>
20	sideband signaling	A method for signaling events and conditions using physical signals separate from signals forming the Link between two components.
	Standard height card	An add-in card whose height is no more than 111.15 mm (4.376 inches)
25	<u>Transmitter path</u>	<u>The path from the transmitter to the connector for a differential data pair (system) or the transmitter to the edge finger (add-in card).</u>
	Up-plugging	Plug <u>Plugging</u> a smaller Link card into a larger Link connector; for example, plugging a x1 card into a x4 connector
30	wakeup	A mechanism used by a component to request the reapplication of main power when in the L2 Link state. Two such mechanisms are defined in the <i>PCI Express Base Specification, Revision 1.12.0</i> : <u>Beacon and</u> <u>_WAKE#</u> . This specification requires the use of WAKE# on any <u>add-</u>
35	<u>in</u>	<u>card or system board that supports wakeup functionality.</u>

1.2. Reference Documents

This specification references the following documents:

- PCI Express Base Specification, Revision ~~1.1~~2.0*
- PCI Local Bus Specification, Revision 3.0*
- PCI Express Jitter Modeling*
- 40 *PCI Express Jitter and BER*

- ❑ *ATX Specification, Revision 2.2*
- ❑ *micro.ATX Motherboard Interface Specification, Revision 1.2*
- ❑ *SMBus Specification, Revision 2.0*
- ❑ *JTAG Specification (IEEE1149.1)*
- 5 ❑ *PCI Standard Hot-Plug Controller and Subsystem Specification, Revision 1.0*
- ❑ *Compact PCI Hot Swap Specification*
- ❑ *EIA-364-1000.01: Environmental Test Methodology for Assessing the Performance of Electrical Connectors and Sockets Used in Business Office Applications*
- ❑ *EIA-364: Electrical Connector/Socket Test Procedures Including Environmental Classifications*

1.3. Specification Contents

10 This specification contains the following information:

- ❑ Auxiliary signals
- ❑ Add-in card hot insertion and removal
- ❑ Power delivery
- ❑ Add-in card electrical budget
- 15 ❑ Connector specification
- ❑ Card form factors and implementation

1.4. Objectives

The objectives of this specification are:

~~Support 2.5 Gb/s data rate (per direction) with headroom for future bandwidth increases~~

- ❑ [Support 5 GT/s data rate \(per direction\)](#)
- 20 ❑ [Support 2.5 GT/s data rate \(per direction\)](#)
- ❑ Enable Hot-Plug and hot swap where they are needed
- ❑ Leverage desktop and server commonality
- ❑ Facilitate smooth transitions
- ❑ Allow co-existence of both PCI and PCI Express add-in cards
- 25 ❑ No chassis or other PC infrastructure changes
- ❑ Forward looking for future scalability
- ❑ Extensible for future bandwidth needs
- ❑ Allows future evolution of PC architecture
- ❑ Maximize card interoperability for user flexibility

- Low cost

1.5. Electrical Overview

The electrical part of this specification covers auxiliary signals, hot insertion and removal, power delivery, and add-in card interconnect electrical budgets for the evolutionary strategy. The PCI Express Transmitter and Receiver electrical requirements are specified in the *PCI Express Base Specification, Revision ~~1.1~~2.0*.

Besides the signals that are required to transmit/receive data on the PCI Express interface, there are also signals that may be necessary to implement the PCI Express interface in a system environment, or to provide certain desired functions. These signals are referred to as the auxiliary signals. They include:

- Reference clock (REFCLK), must be supplied by the system (see Section 2.1.1)
- Add-in card presence detect pins (PRSNT1# and PRSNT2#), required
- PERST#, required
- JTAG, optional
- SMBus, optional
- Wake (WAKE#), required only if the device/system supports wakeup
- +3.3Vaux, optional

REFCLK, JTAG, SMBus, PERST#, and WAKE# are described in Chapter 2; +3.3Vaux is described in Chapter 4; and PRSNT1# and PRSNT2# are described in Chapter 3.

Both Hot-Plug and hot swap of PCI Express add-in cards are supported, but their implementation is optional. Hot-Plug is supported with the evolutionary add-in card form factor. Hot swap is supported with other form factors and will be described in other specifications.

To support Hot-Plug, presence detect pins (PRSNT1# and PRSNT2#) are defined in each end of the connectors and add-in cards. Those presence detect pins are staggered on the add-in cards such that they are last-mate and first-break, detecting the presence of the add-in cards. Chapter 3 discusses the detailed implementation of PCI Express Hot-Plug.

Chapter 4 specifies the PCI Express add-in card electrical requirements, which include power delivery and interconnect electrical budgets. Power is delivered to the PCI Express add-in cards via add-in card connectors, using three voltage rails: +3.3V, +3.3Vaux, and +12V. Note that the +3.3Vaux voltage rail is not required for all platforms (refer to Section 4.1 for more information on the required usage of 3.3Vaux). The maximum add-in card power definitions are based on the card size and Link widths, and are described in Section 4.2. Chapter 4 describes the interconnect electrical budgets, focusing on the add-in card loss and jitter requirements.

1.6. Mechanical Overview

PCI Express can be used in many different applications in desktop, mobile, server, as well as networking and communication equipment. Consequently, multiple variations of form factors and connectors will exist to suit the unique needs of these different applications.

5 Figure 1-1 shows an example of the vertical edge-card PCI Express connector to be used in ATX or ATX-based systems. There will be a family of such connectors, containing one to 16 PCI Express Lanes. The basic bandwidth (BW) version supports one PCI Express Lane and could be used as the replacement for the PCI connector. The high bandwidth version will support 16 PCI Express Lanes and will be used for applications that require higher bandwidth, such as graphics.

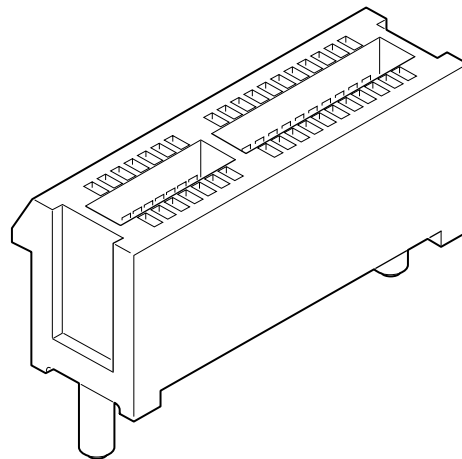

OM14739

Figure 1-1: Vertical Edge-Card Connector

10 Vertical edge card connectors also have applications in the server market segment. Figure 1-2 shows an example of a server configuration using a PCI Express riser card.

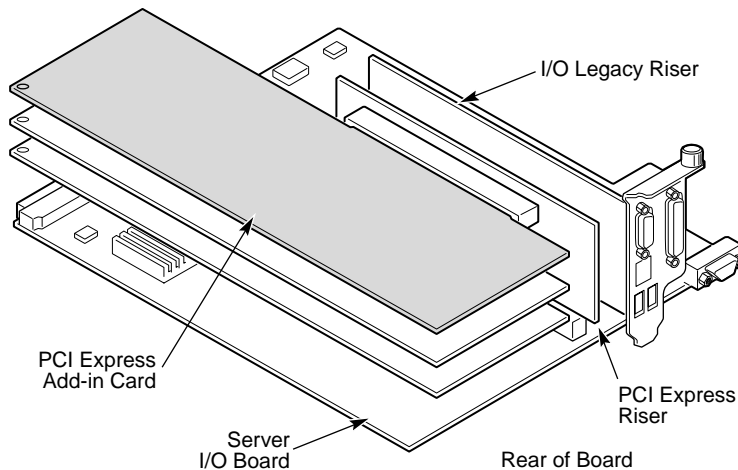

OM14740

Figure 1-2: Example Server I/O Board with PCI Express Slots on a Riser

Mobile applications require a right angle edge card connector. The definition of such a connector will be covered in a separate document.

For certain server and network applications there may also be a need for a Compact PCI-like PCI Express connector, or other backplane-type PCI Express connectors.

- 5 PCI Express cable connectors may also be needed for within-system applications, both internally (inside the chassis) and externally (outside the chassis).

10 While the reality of multiple variations of PCI Express connectors and form factors is recognized, no attempt will be made to define every possible PCI Express connector and form factor variation in this specification. They will be defined later as the need arises in other specifications. This specification, instead, focuses on the vertical edge card PCI Express connectors and form factor requirements by covering the following:

- Connector mating interfaces and footprints
- Electrical, mechanical, and reliability requirements of the connectors, including the connector testing procedures
- 15 Add-in card form factors
- Connector and add-in card locations, as well as keep-outs on a typical desktop system board (ATX/microATX form factor)

Connector definitions and requirements are addressed in Chapter 5 and add-in card form factors and implementation are discussed in Chapter 6.

2

2. Auxiliary Signals

The auxiliary signals are provided on the connector to assist with certain system level functionality or implementation. These signals are not required by the PCI Express architecture. The high-speed signal voltage levels are compatible with advanced silicon processes. The optional low speed signals are defined to use the +3.3V or +3.3Vaux supplies, as they are the lowest common voltage available. Most ASIC processes have high voltage (thick gate oxide) I/O transistors compatible with 3.3 V. Use of the 3.3 V supply allows PCI Express signaling to be used with existing control bus structures, avoiding a buffered set of signals and bridges between the buses.

The PCI Express connector and add-in card interfaces support the following auxiliary signals:

- ❑ REFCLK-/REFCLK+ (required): low voltage differential signals.

Note: Requirements for REFCLK for a system board that support 5 GT/s signaling are defined in *PCI Express Base Specification, Revision 2.0*. A system board that supports 5 GT/s signaling must provide a reference clock that meets all requirements¹ for the common clock architecture defined for the reference clock in the *PCI Express Base Specification, Revision 2.0* and all the requirements defined in this specification. A system board that only support 2.5 GT/s signaling must meet all reference clock requirements in this specification.

- ❑ PERST# (required): indicates when the applied main power is within the specified tolerance and stable. PERST# goes inactive after a delay of T_{PVPERL} time from the power rails achieving specified tolerance on power up.
- ❑ WAKE#: an open-drain, active low signal that is driven low by a PCI Express function to re-activate the PCI Express Link hierarchy's main power rails and reference clocks. It is required on any add-in card or system board that supports wakeup functionality compliant with this specification.
- ❑ SMBCLK (optional): the SMBus interface clock signal. It is an open-drain signal.
- ❑ SMBDAT (optional): the SMBus interface address/data signal. It is an open-drain signal.
- ❑ JTAG (TRST#, TCLK, TDI, TDO, and TMS) (optional): the pins to support *IEEE Standard 1149.1, Test Access Port and Boundary Scan Architecture* (JTAG). They are included as an optional interface for PCI Express devices. IEEE Standard 1149.1 specifies the rules and permissions for designing an 1149.1-compliant IC.
- ❑ PRSNT1# (required): Add-in card presence detect pin. See Chapter 3 for a detailed description.

¹ The RMS jitter requirements are excluded. They are covered under the two port motherboard test methodology and requirements defined in this specification.

- ❑ PRSNT2# (required): ~~Add~~add-in card presence detect pin. See Chapter 3 for a detailed description.

Note that the SMBus interface pins are collectively optional for both the add-in card and the system board. If the optional management features are implemented, SMBCLK and SMBDAT are both required. Similarly, the JTAG pins are collectively optional. If this test mode is implemented, all the JTAG pins are required. Refer to the *PCI Local Bus Specification, Revision. 3.0*, Section 4.3.3 for additional system requirements related to these signals.

2.1. Reference Clock

2.1.1. Low Voltage Swing, Differential Clocks

To reduce jitter and allow for future silicon fabrication process changes, low voltage swing, differential clocks are being used, as illustrated in Figure 2-1. The nominal single-ended swing for each clock is 0 to 0.7 V and a nominal frequency of 100 MHz \pm 300 PPM. The clock has a defined crossover voltage range and monotonic edges through the input threshold regions as specified in Chapter 4.

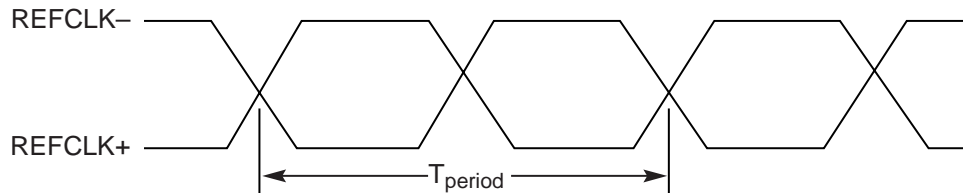

OM14741

Figure 2-1: Differential REFCLK Waveform

The reference clock pair is routed point-to-point to each connector from the system board according to best-known clock routing rules. The reference clock distribution to all devices must be matched to within 15 inches on the system board. The ~~phase~~transport delay ~~delta~~ between the ~~transmitter~~data and ~~receiver~~clock ~~at the Receiver~~ is assumed to be less than 10 ns. The combination of the maximum reference clock mismatch and the maximum channel length will contribute approximately 7-8 ns and the remaining time is allocated to the difference in the insertion delays of the Tx and Rx devices. The routing of each signal in any given clock pair between the clock source and the connector must be well matched in length (< 0.005 inch) and appropriately spaced away from other non-clock signals to avoid excessive crosstalk.

The add-in card is not required to use the reference clock on the connector. However, the add-in card is required to maintain the 600-ppm data rate matching specified in Section 4.3.~~4~~7.1 of the *PCI Express Base Specification, Revision ~~4.1~~2.0*.

Any terminations required by the clock are to be on the system board. An example termination topology for a current-mode clock generator is shown in Figure 2-2. EMI emissions will be reduced if clocks to open sockets are shut down at the clock source. The method for detecting the presence of a card in a slot and controlling the clock gating is platform specific and is not covered in this specification.

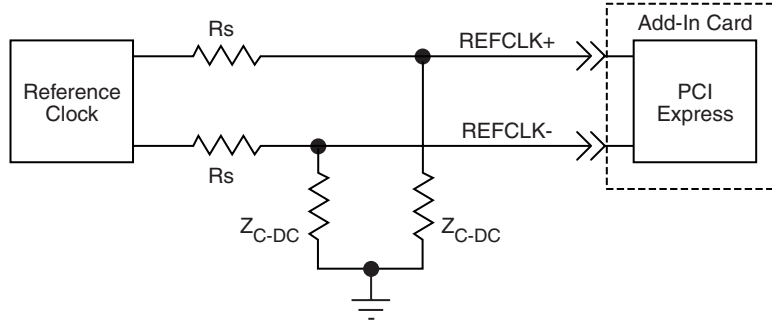

A-0439

Figure 2-2: Example Current Mode Reference Clock Source Termination

Termination on the add-in card is allowed, but is not covered by the specifications in Section 2.1.3. While the same measurement techniques can be used as specified in that section, ~~receiver~~Receiver termination will reduce the nominal swing and rise and fall times by half. The low input swing and low slew rates need to be validated against the clock ~~receiver~~Receiver requirements as they can cause excessive jitter in some clock input buffer designs.

The reference clock timings are based on nominal 100 Ω , differential pair routing with approximately .127-mm (5-mil) trace widths. This timing budget allows for a maximum add-in card trace length of 4.0 inches. No specific trace geometry, however, is explicitly defined in this specification.

2.1.2. Spread Spectrum Clocking (SSC)

The reference clocks may support spread spectrum clocking. Any given system design may or may not use this feature due to platform-level timing issues. The minimum clock period cannot be violated. The ~~preferred~~required method is to adjust the spread technique to not allow for modulation above the nominal frequency. This technique is often called “down-spreading.” The requirements for spread spectrum modulation rate and magnitude are given in the *PCI Express Base Specification, Revision ~~4.1~~2.0*.

2.1.3. REFCLK AC Specifications

All specifications in Table 2-1 are to be measured using a test configuration as described in Note 11 with a circuit as shown in [Figure 2-9](#).

Table 2-1: ~~REFCLK~~REFCLK DC Specifications and AC Timing Requirements

Symbol	Parameter	100 MHz Input		Unit	Note
		Min	Max		
Rise Symbol	Parameter	100 MHz Input		Unit	Note
		Min	Max		
Rising Edge Rate	Rising Edge Rate	0.6	4.0	V/ns	2, 3
Fall Falling Edge Rate	Falling Edge Rate	0.6	4.0	V/ns	2, 3
V _{IH}	Differential Input High Voltage	+150		mV	2
V _{IL}	Differential Input Low Voltage		-150	mV	2
V _{CROSS}	Absolute crossing point voltage	+250	+550	mV	1,4,5
V _{CROSS DELTA}	Variation of V _{CROSS} over all rising clock edges		+140	mV	1,4,9
V _{RB}	Ring-back Voltage Margin	-100	+100	mV	2,12
T _{STABLE}	Time before V _{RB} is allowed	500		ps	2,12
T _{PERIOD AVG}	Average Clock Period Accuracy	-300	+2800	ppm	2,10,13
T _{PERIOD ABS}	Absolute Period (including Jitter and Spread Spectrum modulation)	9.847	10.203	ns	2,6
T _{CCJITTER}	Cycle to Cycle jitter		150	ps	2
V _{MAX}	Absolute Max input voltage		+1.15	V	1,7
V _{MIN}	Absolute Min input voltage		- 0.3	V	1,8
Duty Cycle	Duty Cycle	40	60	%	2
Rise-Fall Matching	Rising edge rate (REFCLK+) to falling edge rate (REFCLK-) matching		20	%	1,14
Z _{C-DC}	Clock source DC impedance	40	60	Ω	1,11

Notes:

1. Measurement taken from single ended waveform.
2. Measurement taken from differential waveform.
3. Measured from -150 mV to +150 mV on the differential waveform (derived from REFCLK+ minus REFCLK-). The signal must be monotonic through the measurement region for rise and fall time. The 300 mV measurement window is centered on the differential zero crossing. See Figure 2-7.
4. Measured at crossing point where the instantaneous voltage value of the rising edge of REFCLK+ equals the falling edge of REFCLK-. See Figure 2-3.
5. Refers to the total variation from the lowest crossing point to the highest, regardless of which edge is crossing. Refers to all crossing points for this measurement. See Figure 2-3.

6. Defines as the absolute minimum or maximum instantaneous period. This includes cycle to cycle jitter, relative PPM tolerance, and spread spectrum modulation. See Figure 2-6.
7. Defined as the maximum instantaneous voltage including overshoot. See Figure 2-3.
8. Defined as the minimum instantaneous voltage including undershoot. See Figure 2-3.
9. Defined as the total variation of all crossing voltages of Rising REFCLK+ and Falling REFCLK-. This is the maximum allowed variance in V_{CROSS} for any particular system. See Figure 2-4.
10. Refer to Section 4.3.2.7.1 of the *PCI Express Base Specification, Revision ~~4.1~~2.0* for information regarding PPM considerations.
11. System board compliance measurements must use the test load card described in [Figure 2-9](#). REFCLK+ and REFCLK- are to be measured at the load capacitors CL. Single ended probes must be used for measurements requiring single ended measurements. Either single ended probes with math or differential probe can be used for differential measurements. Test load $C_L = 2$ pF.
12. T_{STABLE} is the time the differential clock must maintain a minimum ± 150 mV differential voltage after rising/falling edges before it is allowed to droop back into the $V_{RB} \pm 100$ mV differential range. See Figure 2-8.
13. PPM refers to parts per million and is a DC absolute period accuracy specification. 1 PPM is $1/1,000,000^{th}$ of 100.000000 MHz exactly or 100 Hz. For 300 PPM then we have ~~a~~an error budget of $100 \text{ Hz/PPM} * 300 \text{ PPM} = 30 \text{ kHz}$. The period is to be measured with a frequency counter with measurement window set to 100 ms or greater. The ± 300 PPM applies to systems that do not employ Spread Spectrum [Clocking](#) or that use common clock source. For systems employing Spread Spectrum [Clocking](#) there is an additional 2500 PPM nominal shift in maximum period resulting from the 0.5% down spread resulting in a maximum average period specification of +2800 PPM.
14. Matching applies to rising edge rate for REFCLK+ and falling edge rate for REFCLK-. It is measured using a ± 75 mV window centered on the median cross point where REFCLK+ rising meets REFCLK- falling. The median cross point is used to calculate the voltage thresholds the oscilloscope is to use for the edge rate calculations. The Rise Edge Rate of REFCLK+ should be compared to the Fall Edge Rate of REFCLK-, the maximum allowed difference should not exceed 20% of the slowest edge rate. See Figure 2-5.

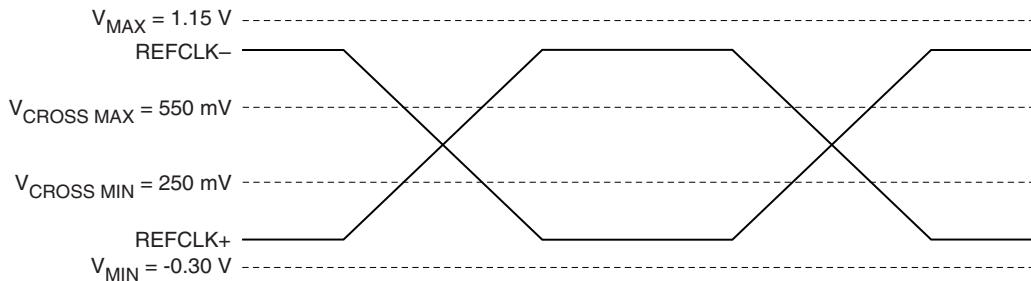

A-0437

Figure 2-3: Single-Ended Measurement Points for Absolute Cross Point and Swing

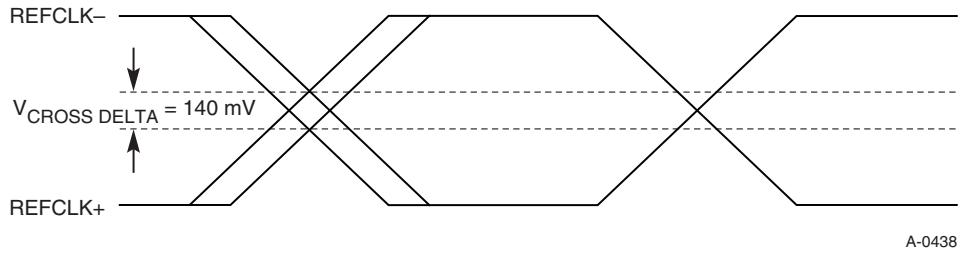

Figure 2-4: Single-Ended Measurement Points for Delta Cross Point

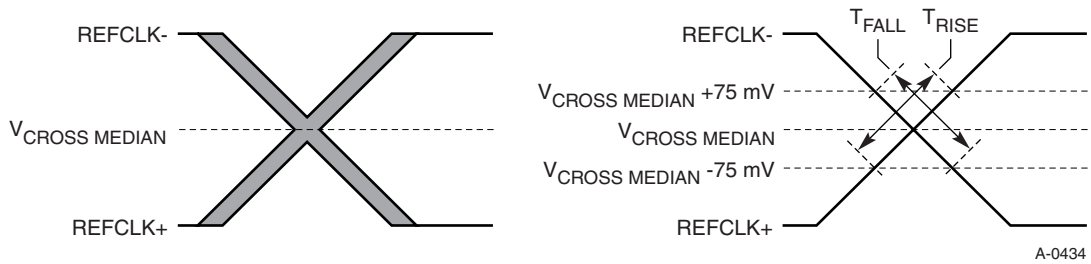

Figure 2-5: Single-Ended Measurement Points for Rise and Fall Time Matching

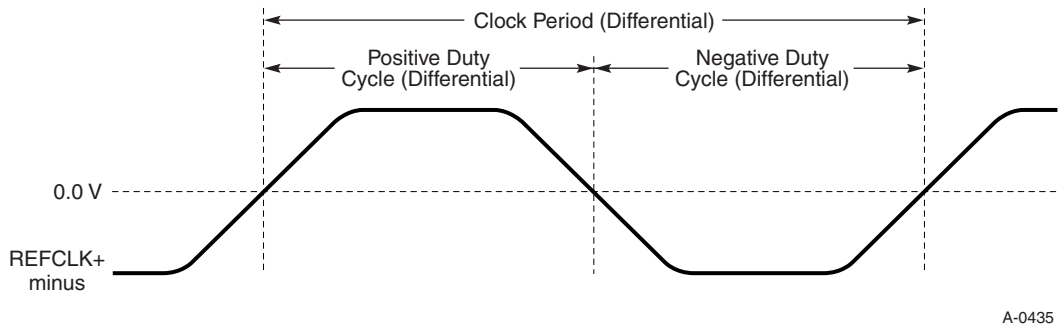

Figure 2-6: Differential Measurement Points for Duty Cycle and Period

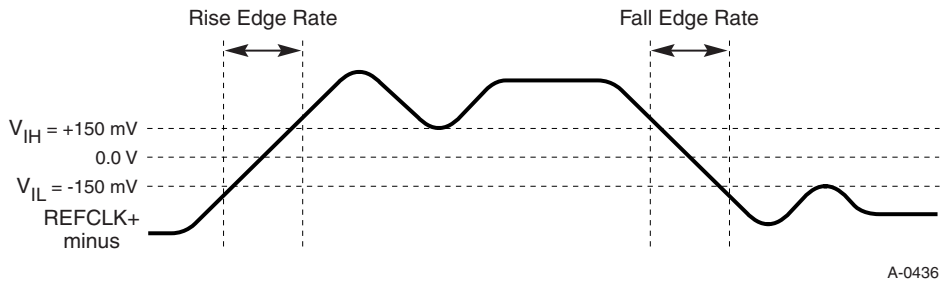

Figure 2-7: Differential Measurement Points for Rise and Fall Time

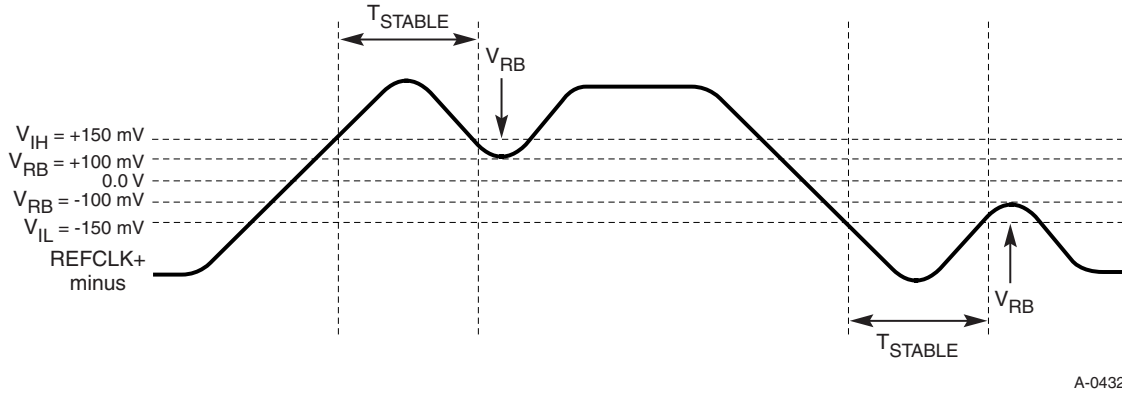

Figure 2-8: Differential Measurement Points for Ringback

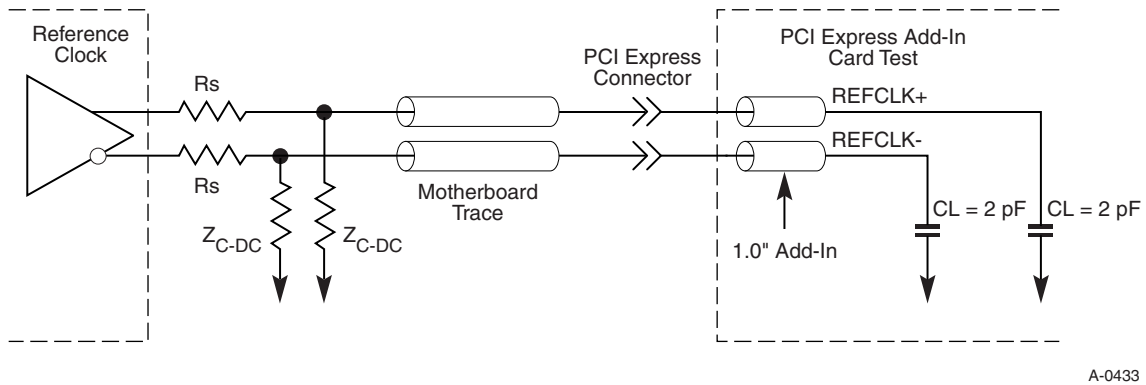

Figure 2-9: Reference Clock System Measurement Point and Loading

2.1.4. REFCLK Phase Jitter Specification [For 2.5 GT/s Signaling Support](#)

The phase jitter of the reference clock is to be measured using the following clock recovery function

$$H(s) = [H_1(s) - H_2(s) * e^{-s * t_{delay}}] \cdot H_3(s)$$

where:

$$H_1(s) = \frac{2s\zeta\omega_1 + \omega_1^2}{s^2 + 2s\zeta\omega_1 + \omega_1^2},$$

$$H_2(s) = \frac{2s\zeta\omega_2 + \omega_2^2}{s^2 + 2s\zeta\omega_2 + \omega_2^2},$$

$$H_3(s) = \frac{s}{s + \omega_3},$$

$$\zeta = 0.54$$

$$\omega_1 = \frac{2 * \pi * 22 \cdot 10^6}{\sqrt{1 + 2\zeta^2} + \sqrt{(1 + 2\zeta^2)^2 + 1}} \text{ Rad / s}$$

$$\omega_2 = \frac{2 * \pi * 1.5 \cdot 10^6}{\sqrt{1 + 2\zeta^2} + \sqrt{(1 + 2\zeta^2)^2 + 1}} \text{ Rad / s}$$

$$\omega_3 = 2 * \pi * 1.5 \cdot 10^6 \text{ Rad / s}$$

$$t_delay = 10 \cdot 10^{-9} \text{ s}$$

The maximum allowed magnitude of the peak-peak reference clock jitter is given in Table 2-2. For information about the maximum peak-peak phase jitter value refer to *PCI Express Jitter Modeling*. Multiple methods can be used to measure the maximum allowed peak-peak phase jitter value. Real time sampling scopes must use a sampling rate of 20 giga-samples per second or better and take enough data to guarantee the proper bit error rate (BER). Reference clock measurements for cards should be taken with a differential, high-impedance probe using the circuit of [Figure 2-9](#) at the load capacitors CL. Measurements for devices on the same board should be made using a differential, high-impedance probe as close to the REFCLK+ and REFCLK- input pins as possible.

Table 2-2: Maximum Allowed Phase Jitter When Applied to Fixed Filter Characteristic

BER ²	Maximum Peak-Peak Phase Jitter Value (ps)
10 ⁻⁶	86
10 ⁻¹²	108

2.1.5. [REFCLK Phase Jitter Specification For 5 GT/s Signaling Support](#)

[This specification does not provide a separate reference clock jitter specification for 5 GT/s signaling support. Instead, a two port methodology for simultaneously assessing the system board data and reference clock is described with specified limits in Section 4.7.5.](#)

2.2. PERST# Signal

The PERST# signal is used to indicate when the power supply is within its specified voltage tolerance and is stable. It also initializes a component's state machines and other logic once power supplies stabilize. On power up, the deassertion of PERST# is delayed 100 ms (T_{PVPERI}) from the power rails achieving specified operating limits. Also, within this time, the reference clocks (REFCLK+, REFCLK-) also become stable, at least $T_{PERST-CLK}$ before PERST# is deasserted. PERST# is asserted in advance of the power being switched off in a power-managed state like S3.

² [These columns provide jitter limits at different BER values on a bathtub curve. If bathtub curves are not used in jitter measurements, then the jitter limit in the 10⁻⁶ column should be used as the total jitter limit for measurements using approximately 10⁶ unit intervals of data.](#)

PERST# is asserted when the power supply is powered down, but without the advanced warning of the transition.

2.2.1. Initial Power-Up (G3 to ~~LOS~~SO)

As long as PERST# is active, all PCI Express functions are held in reset. The main supplies ramp up to their specified levels (3.3 V and 12 V). Some time during this stabilization time, the REFCLK starts and stabilizes. After there has been time (T_{PVPERI}) for the power and clock to become stable, PERST# is deasserted high and the PCI Express functions can start up.

On initial power-up, the hardware default state of the Active State Power Management Control field in the Link Control Register must be set to 00b. The state of this field may be changed by the system BIOS or the operating system only. Other software agents are not allowed to change this field.

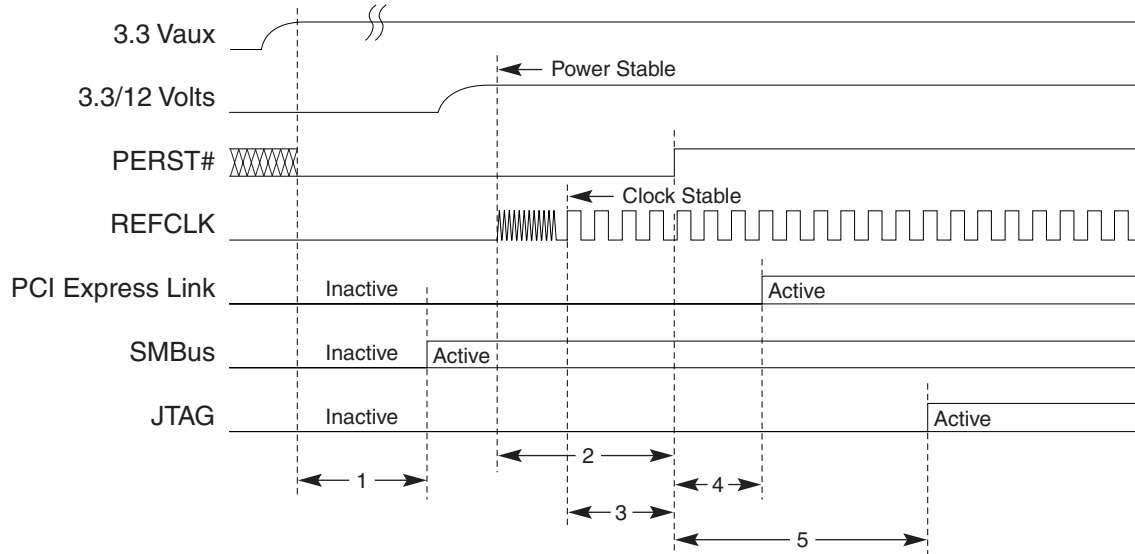

1. 3.3Vaux stable to SMBus driven (optional). If no 3.3Vaux on platform, the delay is from +3.3V stable
2. Minimum time from power rails within specified tolerance to PERST# inactive (T_{PVPERL})
3. Minimum clock valid to PERST# inactive ($T_{PERST-CLK}$)
4. Minimum PERST# inactive to PCI Express link out of electrical idle
5. Minimum PERST# inactive to JTAG driven (optional)

OM14742B

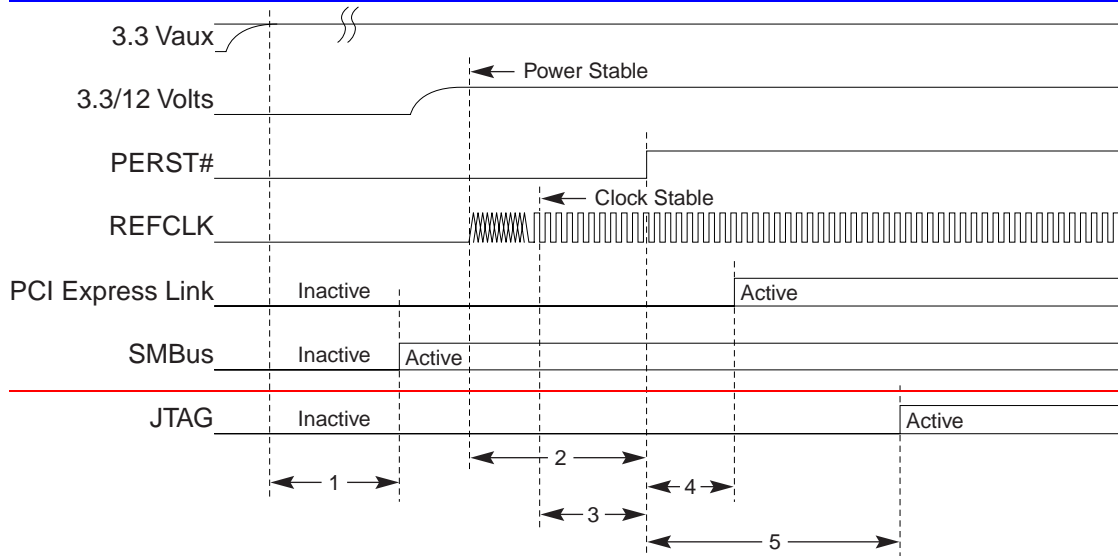

1. 3.3Vaux stable to SMBus driven (optional). If no 3.3Vaux on platform, the delay is from +3.3V stable
2. Minimum time from power rails within specified tolerance to PERST# inactive (T_{PVPERL})
3. Minimum clock valid to PERST# inactive ($T_{PERST-CLK}$)
4. Minimum PERST# inactive to PCI Express link out of electrical idle
5. Minimum PERST# inactive to JTAG driven (optional)

OM14742A

Figure 2-10: Power Up

2.2.2. Power Management States (S0 to S3/S4 to S0)

If the system wants to enter S3/S4, devices are placed into D3_{hot} states with Links in L2 prior to any power transitions at the slot. The main power and reference clock supplied to the PCI Express slot will go inactive and stay inactive until a wakeup event. As a result of the removal of main power, devices enter the D3_{cold} state. During the D3_{cold} state, +3.3V_{aux} remains at 3.3 V. On the wakeup event, the power manager restores the main power and reference clocks. As in the last section, PERST# deasserts T_{PVPERL} after the clocks and power are stable.

On resume from a D3_{cold} state, the hardware default state of the Active State Power Management Control field in the Link Control Register must be set to 00b. The state of this field may be changed by the system BIOS or the operating system only. Other software agents are not allowed to change this field.

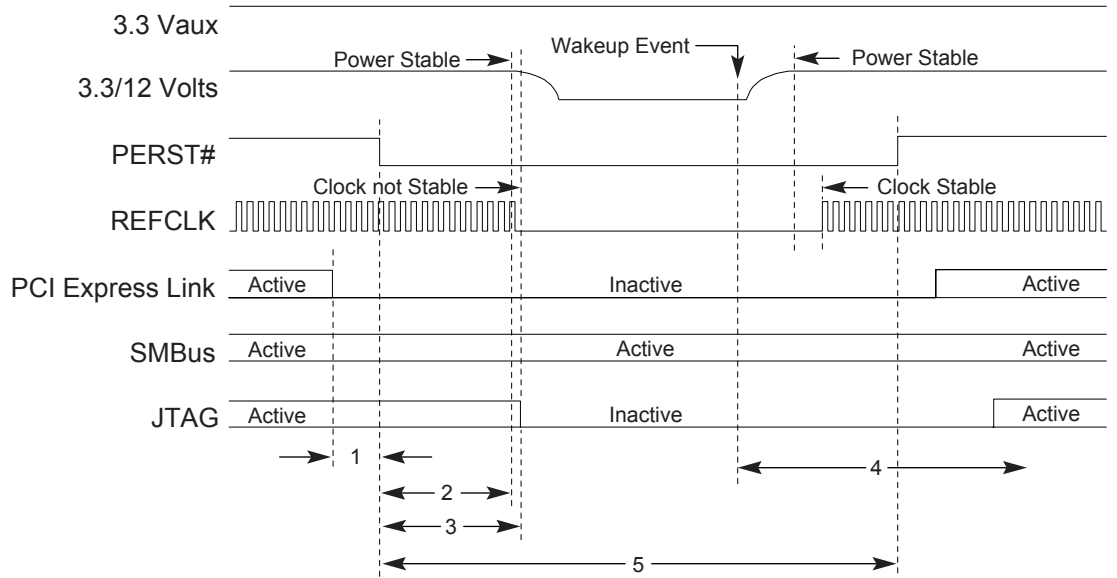

1. The PCI Express link will be put into electrical idle prior to PERST# going active.
2. PERST# goes active before the power on the connector is removed.
3. Clock and JTAG go inactive after PERST# goes active.
4. A wakeup event resumes the power to the connector, restarts the clock, and the sequence proceeds as in power up.
5. The minimum active time for PERST# is T_{PERST} .

OM14743B

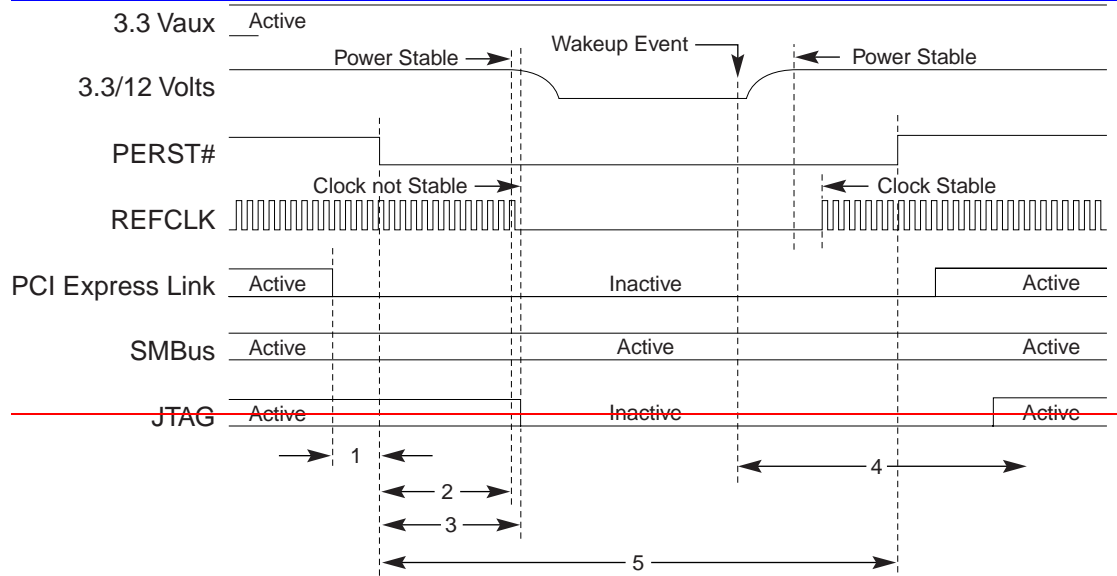

1. The PCI Express link will be put into electrical idle prior to PERST# going active.
2. PERST# goes active before the power on the connector is removed.
3. Clock and JTAG go inactive after PERST# goes active.
4. A wakeup event resumes the power to the connector, restarts the clock, and the sequence proceeds as in power up.
5. The minimum active time for PERST# is T_{PERST} .

OM14743A

Figure 2-11: Power Management States

2.2.3. Power Down

A power rail (12V, 3.3V, or 3.3Vaux) is deemed to be valid or stable if the specified voltage is within the associated voltage tolerances defined in Table 4-1. Once a power rail is deemed stable, an invalid or unstable rail is defined as a rail that has dropped below the specified minimum voltage levels (e.g., below 3.00 V for the 3.3V rails). For purposes of detecting an out-of-tolerance power source, the threshold for detection should be established in a window range of no more than 500 mV below the specified minimum voltage level for the 3.3V and 3.3Vaux rails (i.e., 2.50 V) and 1.34 V below for the 12V rail (i.e., 9.70 V). Figure 2-12 illustrates these threshold windows.

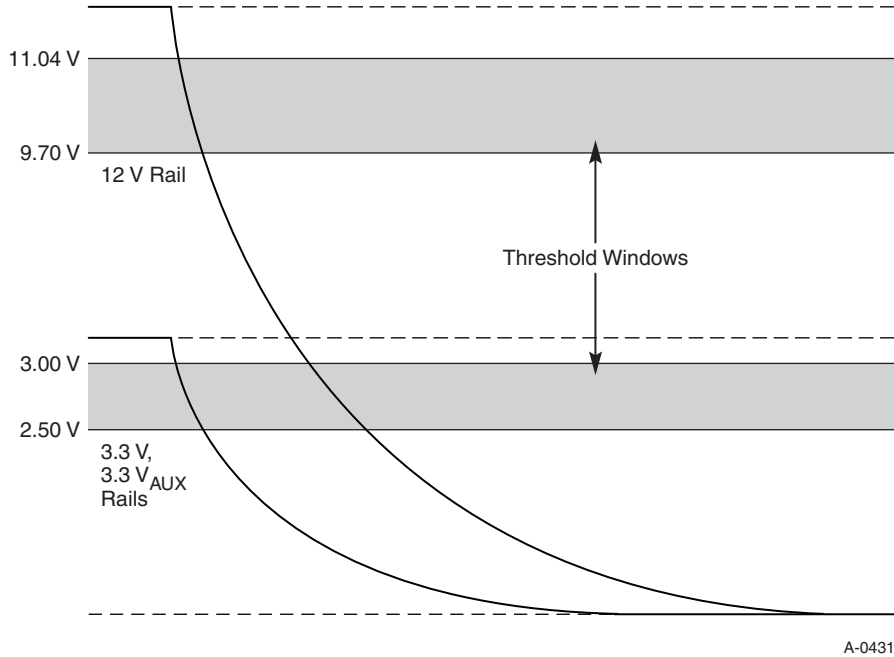
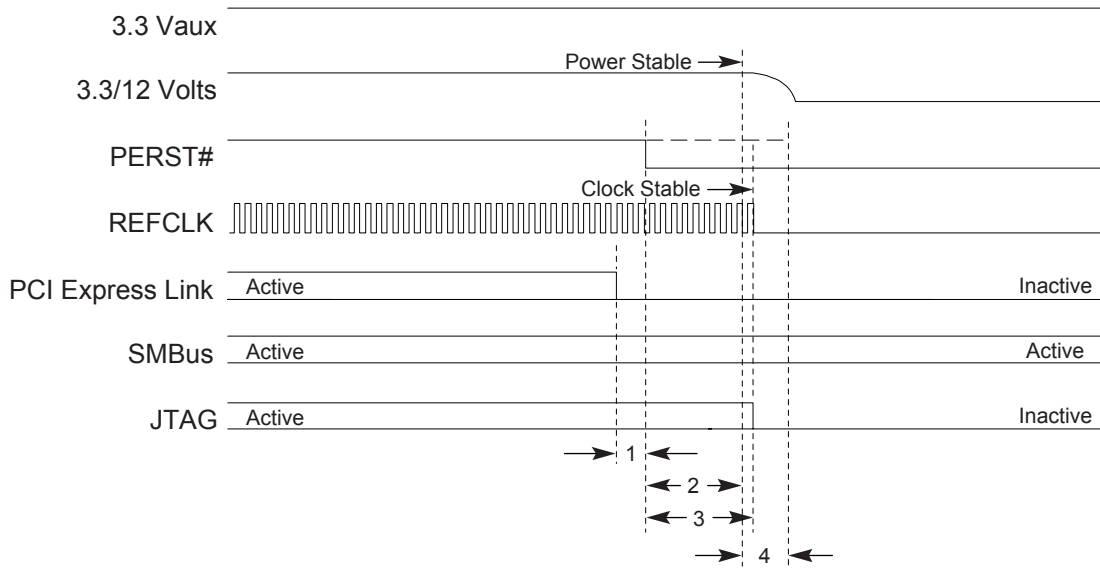
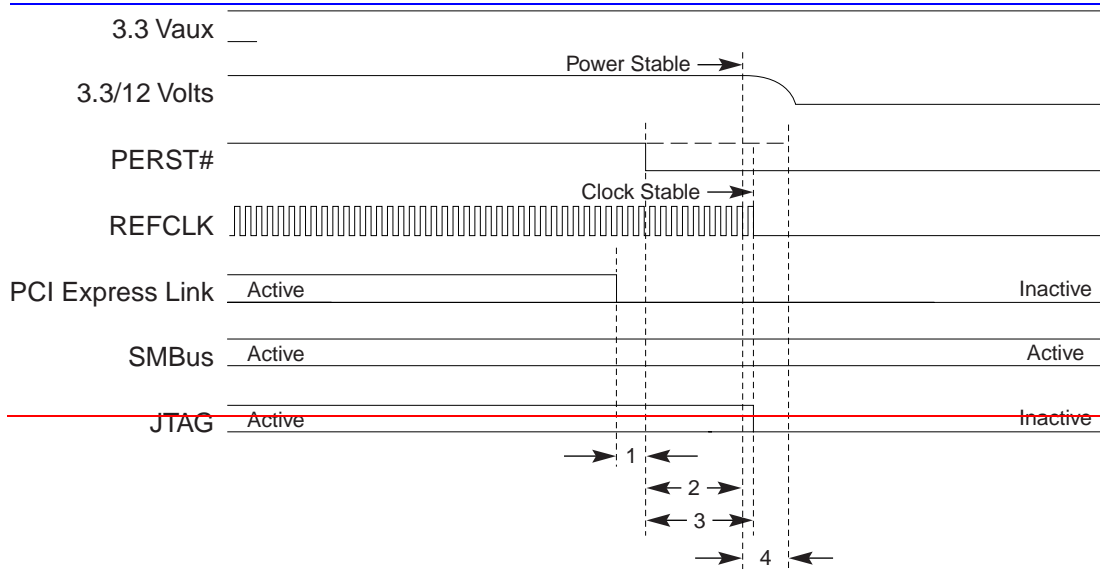

Figure 2-12: Out-of-tolerance Threshold Windows



1. The PCI Express link will be put into an inactive state (Device in D3_{hot}) prior to PERST# going active, except in the case of a surprise power down.
2. PERST# goes active before the power on the connector is removed.
3. Clock and JTAG go inactive after PERST# goes active.
4. In the case of a surprise power down, PERST# goes active T_{FAIL} after power is no longer stable.

OM14744B



1. The PCI Express link will be put into an inactive state (Device in D3_{hot}) prior to PERST# going active, except in the case of a surprise power down.
2. PERST# goes active before the power on the connector is removed.
3. Clock and JTAG go inactive after PERST# goes active.
4. In the case of a surprise power down, PERST# goes active T_{FAIL} after power is no longer stable.

OM14744A

Figure 2-13: Power Down

2.3. WAKE# Signal

The WAKE# signal is an open drain, active low signal that is driven low by a PCI Express component to reactivate the PCI Express slot's main power rails and reference clocks. Only add-in cards that support the wake process connect to this pin. If the add-in card has wakeup capabilities, it must support the WAKE# function. Likewise, only systems that support the wakeup function need to connect to this pin, but if they do, they must fully support the WAKE# function. Such systems are not required to support Beacon as a wakeup mechanism, but are encouraged to support it. If the wakeup process is used, the +3.3Vaux supply must be present and used for this function. The assertion and de-assertion of WAKE# are asynchronous to any system clock. (See Chapter 5 of the *PCI Express Base Specification, Revision ~~4.1~~2.0* for more details on PCI-compatible power management.)

If the WAKE# signal is supported by a slot, the signal is connected to the platform's power management (PM) controller. WAKE# may be bused to all PCI Express add-in card connectors, forming a single input connection at the PM controller or individual connectors can have individual connections to the PM controller. Hot-Plug requires that WAKE# be isolated between connectors and driven inactive during the Hot-Plug/Hot Removal events. Refer to Section 5.1 for the connector pin assignment for the WAKE# signal.

Auxiliary power (+3.3Vaux) must be used by the asserting and receiving ends of WAKE# in order to revive the hierarchy. The system vendor must also provide a pull-up on WAKE# with its bias voltage reference being supplied by the auxiliary power source in support of Link reactivation. Note that the voltage that the system board uses to terminate the WAKE# signal can be lower than the auxiliary supply voltage to be compatible with lower voltage processes of the system PM controller. However, all potential drivers of the WAKE# signal must be 3.3 V tolerant.

Note: WAKE# is not PME# and should not be attached to the PCI-PME# interrupt signals. WAKE# causes power to be restored but must not directly cause an interrupt.

WAKE# has additional electrical requirements over and above standard open drain signals that allow it to be shared between devices that are powered off and those that are powered on using auxiliary power for example. The additional requirements include careful circuit design to ensure that a voltage applied to the WAKE# signal network never causes damage to a component even if that particular component's power is not applied.

Additionally, the device must ensure that it does not pull WAKE# low unless WAKE# is being intentionally asserted in all cases, including when the related function is in D3_{cold}.

This means that any component implementing WAKE# must be designed such that:

- ❑ Unpowered WAKE# output circuits are not damaged if a voltage is applied to them from other powered "wire-ORed" sources of WAKE#.
- ❑ When power is removed from its WAKE# generation logic, the unpowered output does *not* present a low impedance path to ground or any other voltage.

These additional requirements ensure that the WAKE# signal network continues to function properly when a mixture of auxiliary powered, and unpowered components have their WAKE# outputs wire-ORed together. It is important to note that most commonly available open drain, and tri-state buffer circuit designs used "as is" do not satisfy the additional circuit design requirements for WAKE#.

Other requirements on the system board/add-in card designer include:

- ❑ Common ground plane reference between slots/components attached to the same WAKE# signal.
- 5 ❑ Split voltage power planes (+3.3Vaux vs. +3.3V) are required if +3.3Vaux is supplied to the connector(s).
- ❑ If +3.3Vaux is supplied to one PCI Express connector in a chassis, it must be supplied to all PCI Express connectors in that chassis.
- ❑ If WAKE# is supported on one PCI Express connector in a chassis, it must be supported on all PCI Express connectors in that chassis.
- 10 ❑ If the system does not support +3.3Vaux or the wakeup function, the +3.3Vaux connector pin is left open on the system board. See the *PCI Bus Power Management Interface Specification, Revision 1.2* for +3.3Vaux power requirements.
- ❑ +3.3Vaux voltage supply may be present even if the device is not enabled for wakeup events.
- ❑ +3.3V at the PCI Express connector may be switched off by the system.
- 15 ❑ Add-in cards are permitted to generate the Beacon wakeup mechanism in addition to using the WAKE# mechanism, although the system is not required to provide support for Beacon.

Note: If the add-in card uses the Beacon mechanism in addition to the WAKE# mechanism, the Beacon may be ignored by the system. Circuits that support the wake function and are intended to work in any PCI Express system must be designed to generate the Beacon on their PCI Express data lines.

20 PCI Express add-in card designers must be aware of the special requirements that constrain WAKE# and ensure that their add-in cards do not interfere with the proper operation of the WAKE# network. The WAKE# input into the system may de-assert as late as 100 ns after the WAKE# output from the function de-asserts (i.e., the WAKE# pin must be considered
25 indeterminate for a number of cycles after it has been de-asserted).

The value of the pull-up resistor for WAKE# on the system board must be derived taking into account the total possible capacitance on WAKE# to ensure that WAKE# charges up to a logic high voltage level in no more than 100 ns. (See Section 4.3.3 of the *PCI Local Bus Specification, Revision 3.0* for information on pull-up resistors.)



IMPLEMENTATION NOTE

Example WAKE# Circuit Design

The following diagram is an example of how the WAKE# generation logic could be implemented. In this example, multiple PCI Express functions have their WAKE# signals ganged together and connected to the single WAKE# pin on the PCI Express add-in card connector.

The circuit driving the gate of transistor Q1 is designed to isolate the add-in card's WAKE# network from that of the system board whenever its power source (V_{SOURCE}) is absent.

If the card supplies power to its WAKE# logic with the PCI Express connector's 3.3 V supply (i.e., it does not support wakeup from $D3_{cold}$), then all WAKE# sources from the card will be isolated from the system board when the add-in card's +3.3V rail is switched off. Add-in cards that support wakeup from $D3_{cold}$ have an auxiliary power source (+3.3V_{aux}) to power the WAKE# logic which maintains connection of these WAKE# sources to the system board's WAKE# signal network even when the Link hierarchy's power (+3.3V) has been switched off.

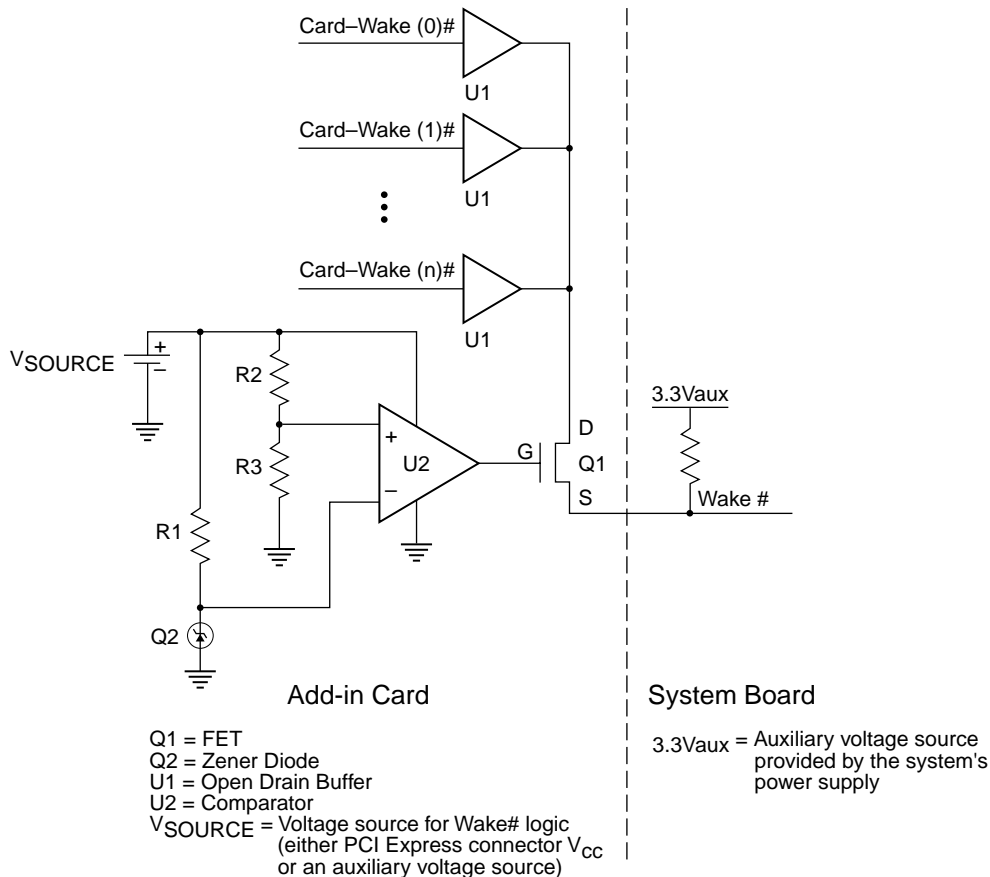

OM14749

This example assumes that all sources of WAKE# on the add-in card are powered by either the +3.3V or +3.3V_{aux} (V_{SOURCE}). If WAKE# from $D3_{cold}$ is supported by some, but not all of the add-

in card's functions that generate WAKE#, the add-in card designer must ensure that there is separate isolation control for each of the WAKE# generation power sources.

PCI Express component designers could choose to integrate the “power fail detect” isolation circuitry with their WAKE# output pin physically corresponding to the source of FET Q1. Alternatively, all isolation control logic could be implemented externally on the add-in card.

This example is meant as a conceptual aid, and is not intended to prescribe an actual implementation.

2.4. SMBus (Optional)

The optional System Management Bus (SMBus) is a two-wire interface through which various system component chips can communicate with each other and with the rest of the system. It is based on the principles of operation of I²C.

SMBus provides a control bus for system and power management related tasks. A system may use SMBus to pass messages to and from devices instead of tripping individual control lines. Removing the individual control lines reduces pin count. Accepting messages ensures future expandability.

With SMBus, a device can provide manufacturer information, tell the system what its model/part number is, save its state for a suspend event, report different types of errors, accept control parameters, and return its status.

SMBus is described in *System Management Bus (SMBus) Specification, Version 2.0*. Refer to this specification for DC characteristics and all AC timings. If the system board or add-in card supports SMBus, it must adhere to additional requirements that may be found in Chapter 8 of the *PCI Local Bus Specification, Revision. 3.0*.

The system board provides pull-ups to the +3.3V_{aux} rail per the above specification and the components attached to these signals need to have a 3.3 V signaling tolerance.

2.4.1. Capacitive Load of High-power SMBus Lines

Capacitive load for each bus line includes all pin, wire, and connector capacitances. The maximum capacitive load affects the selection of the pull-up resistor or the current source in order to meet the rise time specifications of SMBus.

Normally, pin capacitance is defined as the total capacitive load of one SMBus device as seen in a typical manufacturer's data sheet. The value in the DC specifications (C_{OUT} in Table 2-3) is a recommended guideline so that two SMBus devices may, for example, be populated on an add-in card.

2.4.2. Minimum Current Sinking Requirements for SMBus Devices

While SMBus devices used in low-power segments have practically no minimum current sinking requirements due to the low pull-up current specified for low-power segments, devices in high-power segments are required to sink a minimum current of 4 mA while maintaining the $V_{OL(max)}$ of 0.4 V. The requirement for 4 mA sink current determines the minimum value of the pull-up resistor R_p that can be used in SMBus systems.

2.4.3. SMBus “Back Powering” Considerations

Unpowered devices connected to either a low-power or high-power SMBus segment must provide, either within the device or through the interface circuitry, protection against “back powering” the SMBus. Unpowered devices connected to high-power segments must meet leakage specifications in Section 3.1.2.1 of the *System Management Bus (SMBus) Specification, Version 2.0*.

2.4.4. Power-on Reset

SMBus devices detect a power-on event in one of three ways:

- By detecting that power is being applied to the device
- By PERST# being asserted
- For self-powered or always powered devices, by detecting that the SMBus is active (clock and data lines have gone high after being low for more than 2.5 s)

An SMBus device must respond to a power-on event by bringing the device into an operational state within t_{POR} , defined in Table 1 of the *System Management Bus (SMBus) Specification, Version 2.0*, after the device has been supplied power that is within the device’s normal operating range. Self-powered or always-powered devices, such as Smart Batteries, are not required to do a complete power-on reset but they must be in an operational state within 500 ms after the SMBus becomes active.

2.5. JTAG Pins (Optional)

The *IEEE Standard 1149.1, Test Access Port and Boundary Scan Architecture*, is included as an optional interface for PCI Express devices. *IEEE Standard 1149.1* specifies the rules and permissions for designing an 1149.1-compliant interface. Inclusion of a Test Access Port (TAP) on an add-in card allows boundary scan to be used for testing of the card on which it is installed. The TAP is comprised of four pins (optionally five) that are used to interface serially with a TAP controller within the PCI Express device.

5	TCK	in	<i>Test Clock</i> is used to clock state information and test data into and out of the device during operation of the TAP.
10	TDI	in	<i>Test Data Input</i> is used to serially shift test data and test instructions into the device during TAP operation.
	TDO	out	<i>Test Output</i> is used to serially shift test data and test instructions out of the device during TAP operation.
	TMS	in	<i>Test Mode Select</i> is used to control the state of the TAP controller in the device.
15	TRST#	in	<i>Test Reset</i> provides an asynchronous initialization of the TAP controller. This signal is optional in <i>IEEE Standard 1149.1</i> .

These TAP pins operate at 3.3V, the same as the other single-ended I/O signals of the PCI Express connector. The drive strength of the TDO pin is not required to be the same as other PCI Express pins. The add-in card vendor must specify TDO drive strength. The direction of these TAP pins is defined from the perspective of the add-in card.

The system vendor is responsible for the design and operation of the 1149.1 serial chains (“rings”) required in the system. The signals are supplementary to the PCI Express interface. Additional information can be found in the *PCI Local Bus Specification, Revision. 3.0*, Section 2.2.9.

2.6. Auxiliary Signal Parametric Specifications

2.6.1. DC Specifications

Table 2-3: Auxiliary Signal DC Specifications - PERST#, WAKE#, and SMBus

Symbol	Parameter	Conditions	Min	Max	Unit	Notes
V_{IL1}	Input Low Voltage		-0.5	0.8	V	2
V_{IH1}	Input High Voltage		2.0	$V_{cc3_3} + 0.5$	V	2
V_{IL2}	Input Low Voltage		-0.5	0.8	V	4
V_{IH2}	Input High Voltage		2.1	$V_{ccSus3_3} + 0.5$	V	4
V_{OL1}	Output Low Voltage	4.0 mA		0.2	V	1, 3
V_{HMAX}	Max High Voltage			$V_{cc3_3} + 0.5$	V	3
V_{OL2}	Output Low Voltage	4.0 mA		0.4	V	1, 4
I_{in}	Input Leakage Current	0 to 3.3 V	-10	+10	μ A	2, 4
I_{Ikg}	Output Leakage Current	0 to 3.3 V	-50	+50	μ A	3, 5
C_{in}	Input Pin Capacitance			7	pF	2
C_{out}	Output (I/O) Pin Capacitance			30	pF	3,4

Notes:

1. Open-drain output a pull-up is required on the system board. There is no V_{OH} specification for these signals. The number given is the maximum voltage that can be applied to this pin.
2. Applies to PERST#.
3. Applies to WAKE#.
4. Applies to SMBus signals SMBDATA and SMBCLK.
5. Leakage at the pin when the output is not active (high impedance).

2.6.2. AC Specifications

Table 2-4: Power Sequencing and Reset Signal Timings

Symbol	Parameter	Min	Max	Units	Notes	Figure
T_{PVPERL}	Power stable to PERST# inactive	100		ms	1	Figure 2-10
$T_{PERST-CLK}$	REFCLK stable before PERST# inactive	100		μ s	2	Figure 2-10
T_{PERST}	PERST# active time	100		μ s		Figure 2-11
T_{FAIL}	Power level invalid to PERST# active		500	ns	3	Figure 2-13
T_{WKRF}	WAKE# rise – fall time		100	ns	4	Figure 2-14

Notes:

1. Any supplied power is stable when it meets the requirements specified for that power supply.
2. A supplied reference clock is stable when it meets the requirements specified for the reference clock. The PERST# signal is asserted and de-asserted asynchronously with respect to the supplied reference clock.
3. The PERST# signal must be asserted within T_{FAIL} of any supplied power going out of specification.
4. Measured from WAKE# assertion/de-assertion to valid input level at the system PM controller. Since WAKE# is an open-drain signal, the rise time is dependent on the total capacitance on the platform and the system board pull-up resistor. It is the responsibility of the system designer to meet the rise time specification.

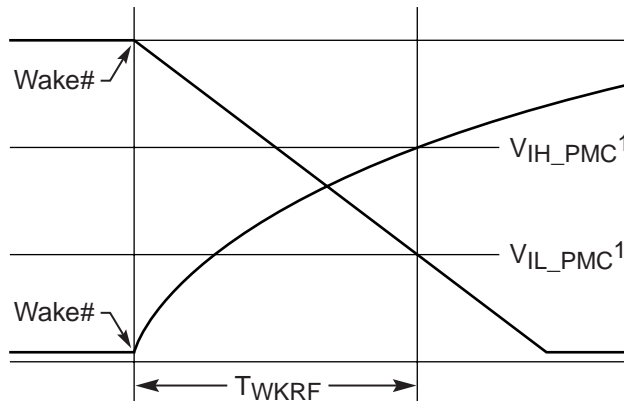

Note 1: Power Management Controller input switching levels are platform dependent and are not set by this specification.

A-0338

Figure 2-14: WAKE# Rise and Fall Time Measurement Points

3

3. Hot Insertion and Removal

In the following text, all references to mechanical elements should be interpreted in the context of the PCI Express card form factor definition, unless otherwise stated.

3.1. Scope

5 The PCI Express specification natively supports Hot-Plug/Hot Removal of PCI Express add-in cards. However, hardware support of Hot-Plug/Hot-Removal on the system board is optional. Since the PCI Express evolutionary form factor is designed as a direct PCI connector replacement and utilizes an edge card connector, the PCI Express Native Hot-Plug model is based on the standard usage model defined in the *PCI Standard Hot-Plug Controller and Subsystem Specification, Revision 1.0*.

10 The following section describes the add-in card presence detect and PCI Express Native Hot-Plug signals. For a detailed explanation of the register requirements and standard usage model, see Chapter 7 of the *PCI Express Base Specification, Revision ~~4.1~~2.0*.

3.2. Presence Detect

15 The PCI Express Hot-Plug controller detects the presence of an add-in card using the PRSNT2# signal as shown in Figure 3-1. It is the responsibility of the Root Complex or the ~~switch~~Switch to determine the presence of the add-in card and set the present bits in the appropriate register as described in Chapter 7 of the *PCI Express Base Specification, Revision ~~4.1~~2.0*. In addition to the Hot-Plug controller, the PRSNT2# signal is used by the system board to recognize the presence of the add-in card in order to enable the auxiliary signals: REFCLK, PERST#, SMBus group, and JTAG group. The two signals, PRSNT1# and PRSNT2#, described in Figure 3-1, are required on the PCI
20 Express connector and must be supported by all PCI Express add-in cards.

Both PRSNT1# and PRSNT2# signals are required in order to detect the presence of the add-in card and to ensure that it is fully inserted in the connector. Note that the pads on the add-in card for the PRSNT1# and PRSNT2# signals are shorter than the rest of the pads in order to have about
25 1 ms difference of insertion time. Unused PRSNT2# pads on x4, x8, and x16 add-in cards can be either standard length or the pad can be eliminated. This scheme is used to allow the power switches to isolate the power to the card during surprise removal. The mechanical details are provided in Chapter 5.

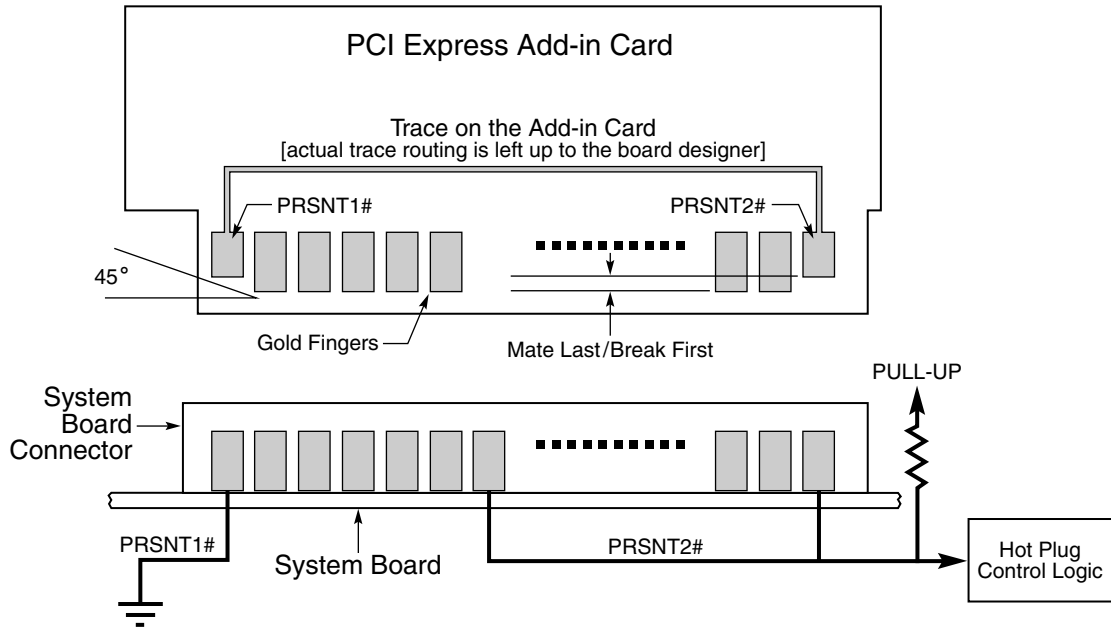

OM14750A

Figure 3-1: Presence Detect in a Hot-Plug Environment

It is required that all PCI Express add-in cards implement variable-length edge finger pads and tie the PRSNT1# and PRSNT2# signals together on the add-in card. There is more than one PRSNT2# pin defined in the x4, x8, and x16 PCI Express connectors; these are needed to support up-plugging. All add-in cards shall connect the PRSNT1# signal to the farthest-apart PRSNT2# signal with a single trace in between them as illustrated in Figure 3-1. For example, a x4 add-in card would connect PRSNT1# with PRSNT2# on pin B31, and a x8 add-in card would connect PRSNT1# with PRSNT2# on pin B48. Refer to Table 5-1 for connector pin numbering and definition. If the system board designer chooses to implement hot-plug support, the system board must connect PRSNT1# to GND and separately connect all the PRSNT2# pins together to a single pull-up resistor, as shown in Figure 3-1. The system board designer determines the pull-up resistor voltage and associated use of applicable hot-plug control logic. If the system board designer chooses not to implement hot-plug support, PRSNT1# and PRSNT2# connector pins may either be left un-connected or may be grounded on the system board.

Since the x8 add-in card may plug into a x8 connector with a x4 Link only, the system board shall have the two PRSNT2# pins (B31 and B48) connected together. This is required in order to sense the presence of the x8 add-in card in a x8 connector that supports a x4 Link only. See Section 6.3 for card interoperability discussions.

4

4. Electrical Requirements

Power delivery requirements defined in this chapter apply not only to add-in cards, but also to connectors and systems.

4.1. Power Supply Requirements

All PCI Express add-in card connectors require two power rails: +12V and +3.3V, with a third, optional 3.3Vaux rail. Systems that provide PCI Express add-in card connectors are required to provide both the +12V and +3.3V rails to every PCI Express add-in card connector in the system. The 3.3Vaux rail may be supplied to the PCI Express add-in card connectors at the system board designers' discretion. However, if a system board designer does supply 3.3Vaux to the PCI Express add-in card connector, the 3.3Vaux rail must be supplied to all PCI Express add-in card connectors. In addition, as described in Chapter 2, if the platform with the PCI Express interface supports the WAKE# signal, the 3.3Vaux rail (as well as the WAKE# signal) must be supplied to all PCI Express add-in card connectors.

Table 4-1 provides the required specifications for the power supply rails available at the PCI Express slots. The system designer is responsible for ensuring that the power delivered to the PCI Express connectors meets the specifications called out in Table 4-1.

Table 4-1: Power Supply Rail Requirements

Power Rail	10 W Slot	25 W Slot	75 W Slot
+3.3V			
Voltage tolerance	± 9% (max)	± 9% (max)	± 9% (max)
Supply Current	3.0 A (max)	3.0 A (max)	3.0 A (max)
Capacitive Load	1000 µF (max)	1000 µF (max)	1000 µF (max)
+12V			
Voltage tolerance	± 8%	± 8%	± 8%
Supply Current	0.5 A (max)	2.1 A (max)	5.5 A (max)
Capacitive Load	300 µF (max)	1000 µF (max)	2000 µF (max)

Power Rail	10 W Slot	25 W Slot	75 W Slot
+3.3Vaux			
Voltage tolerance	± 9% (max)	± 9% (max)	± 9% (max)
Supply Current			
Wakeup Enabled	375 mA (max)	375 mA (max)	375 mA (max)
Non-wakeup Enabled	20 mA (max)	20 mA (max)	20 mA (max)
Capacitive Load	150 µF (max)	150 µF (max)	150 µF (max)

Notes:

1. The maximum current slew rate for each add-in card shall be no more than 0.1 A/µs.
2. Each add-in card shall limit its bulk capacitance on each power rail to less than the values shown in Table 4-1.
3. System boards that support Hot-Plug add-in cards shall limit the voltage slew rate so that the inrush current to the card shall not exceed the specified maximum current. This is calculated by the equation $dV/dt = I/C$; where:
 I = maximum allowed current (A)
 C = maximum allowed bulk capacitance (F)
 dV/dt = maximum allowed voltage slew rate (V/s)

4.2. Power Consumption

This specification provides various sizes of cards for system implementation. Each card size provides support for a certain number of PCI Express lanes, and a corresponding difference in specified power consumption as shown in Table 4-2.

Table 4-2: Add-in Card Power Dissipation

	X1		x4/x8	x16	
Standard height	10 W ¹ (max)	25 W ¹ (max)	25 W (max)	25 W ² (max)	75 W ^{2,4} (max)
Low profile card ³	10 W (max)		25 W (max)	25 W (max)	

Notes:

1. A standard height x1 add-in card intended for desktop applications is limited in length to a half-length add-in card and 10 W maximum power dissipation. A standard height x1 add-in card intended for server I/O applications with 25 W maximum power dissipation must be greater than or equal to 177.80 mm (7.0 inches) in length, but must not exceed a full-length add-in card. See Table 6-1 for add-in card size definitions. The same server I/O add-in card must, at initial power-up, not exceed 10 W of power dissipation, until configured as a high power device, at which time it must not exceed 25 W of power dissipation. Refer to Chapter 6 of the *PCI Express Base Specification, Revision 1.1* for information on the power configuration mechanism.
2. A standard height x16 add-in card intended for server I/O applications must limit its power dissipation to 25 W. A standard height x16 add-in card intended for graphics applications must, at initial power-up, not exceed 25 W of power dissipation, until configured as a high power device, at which time it must not exceed 75 W of power dissipation. Refer to Chapter 6 of the *PCI Express Base Specification, Revision ~~1.1~~2.0* for information on the power configuration mechanism.
3. All low profile add-in cards are limited in length to a half-length add-in card and must not exceed the power dissipation values shown in Table 4-2.

4. A x16 graphics card is limited to 75 W. The 75 W maximum can be drawn via the combination of +12V and +3.3V rails, but each rail draw is limited as defined in Table 4-1, and the sum of the draw on the two rails cannot exceed 75 W.

The power limits for respective connector widths, x1, x4/x8, and x16, represent the add-in card and system capacity to provide cooling for the slot. The 10 W limit assumes natural convection cooling in a system that provides air exchanges. The 25 W and above add-in card power limits assume that sufficient cooling is provided to the slot by the cards in the present chassis environment. In general, the power limits above assume a chassis environment with a maximum internal temperature of 55°C on the primary component side of the add-in card and natural convection cooling in a system that provides air exchanges. Implementations of other chassis environments should pay special attention to system level thermal requirements.

PCI Express allows for higher maximum power for graphics cards than AGP. In case such a graphics card is used in a system, implementers should pay special attention to system level thermal, acoustic, structure, and power delivery requirements. To insure optimum performance, it is recommended that the system designer refer to the *PCI Express Graphics Card Thermal and Mechanical Guideline for Desktop Systems*.



IMPLEMENTATION NOTE

Software Update of the Slot Power Limit

System firmware must update the slot power limit to the system's allocated value for the PCI Express add-in card (e.g., graphics) and ensure the completion of this update prior to invoking the option ROM for that add-in card's PCI Express function. If the initial slot power limit value is set by hardware initialization, then any attempt by software to change that value must be verified by that software prior to initializing the add-in card. Subsequent updates by the system firmware or operating system software, if any, may only increase the slot power limit value. However, after a card is reset, the initial slot power limit value may be lower than the previous value. The maximum power level for an add-in card must be assigned by the system firmware during PCI Express configuration. For graphics, the power level assigned will be dependent on the platform's support of the *PCI Express x16 Graphics 150W-ATX Specification, Revision 1.0* (including the supplemental power cable).

4.3. Power Supply Sequencing

There is no specific requirement for power supply sequencing of each of the three power supply rails. They may come up or go down in any order. The system, however, must assert the PERST# signal whenever any of the three power rails goes outside of the specifications provided in Table 4-1 (refer to Section 2.1.5 for specific information on the function and proper use of the PERST# signal).

Note: If a PCI Express add-in card requires power supply rail sequencing, it is the responsibility of the add-in card designer to provide appropriate circuitry on the add-in card to meet any power supply rail sequencing requirements.

4.4. Power Supply Decoupling

Due to the low level signaling of the PCI Express interface, it is strongly recommended that sufficient decoupling of all power supplies be provided. This is recommended to ensure that power supply noise does not interfere with the recovery of data from a remote upstream PCI Express device. Some basic guidelines to help ensure a quiet power supply are provided below.

- 5 Note: The following are guidelines only. It is the responsibility of the add-in card designer to properly test the design to ensure that add-in card circuitry does not create excessive noise on power supply or ground signals at the add-in card edge fingers.
- ❑ The add-in card device decouple value should average 0.01 μF per device V_{cc} pin (for all devices on the add-in card).
 - 10 ❑ The trace length between a decoupling capacitor and the power supply or ground via should be less than 0.2 inches (5.08 mm) and be a minimum of 0.02 inches (0.508 mm) in width.
 - ❑ A bulk decoupling capacitor (greater than 10 μF) is recommended at the add-in card edge finger for each power supply.
 - 15 ❑ A bulk decoupling capacitor (greater than 10 μF) is recommended on each power supply used within a device on the add-in card. This bulk decoupling capacitor should be in close proximity to the add-in card device.

4.5. Electrical Topologies and Link Definitions

The remainder of this chapter describes the electrical characteristics of PCI Express add-in cards. The electrical characteristic at the card interface is defined in terms of electrical budgets. This budget allocation decouples the electrical specification for the system designer and the card vendor and ensures successful communication between the PCI Express signal input and output Links at the system board and add-in card interface. Unless otherwise noted, the specifications contained herein apply to all high-speed signals of each interface width definition. The signaling rate for encoded data is 5 GT/s, or 2.5 ~~G-transfers~~GT/s and the signaling is point-to-point. Requirements are called out separately for 5 GT/s and 2.5 GT/s signaling rates. A CEM device that supports the 5 GT/s rate must also support the 2.5 GT/s rate.

4.5.1. Topologies

~~There are three different~~ Three possible electrical topologies for PCI Express are:

- ❑ PCI Express devices on the same system board
- ❑ PCI Express devices across one connector on a system with a system board and an add-in card
- 30 ❑ PCI Express devices across two connectors on a system with a system board, ~~a~~ a riser card, and an add-in card

This specification supports only the one and two connector topologies. The “PCI Express on-board” configuration is used for two-PCI Express devices on a common PCB (see Figure 4-1). Since there are no add-in cards involved in this topology, refer to the *PCI Express Base Specification, Revision ~~4.1~~2.0* for implementation of this topology.

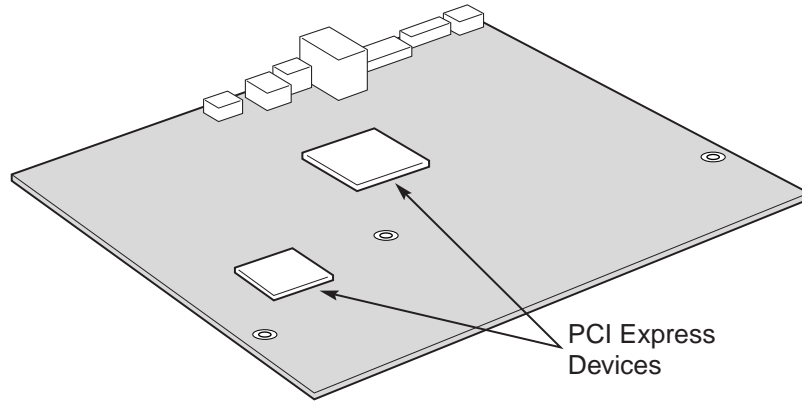

OM14751

Figure 4-1: PCI Express on the System Board

The topology of “PCI Express with one connector” allows a plug-in PCI Express add-in card similar to a standard PCI or AGP add-in card to interface with a system board using a PCI Express vertical edge connector (Figure 4-2). In this topology, only one connector-card interface exists.

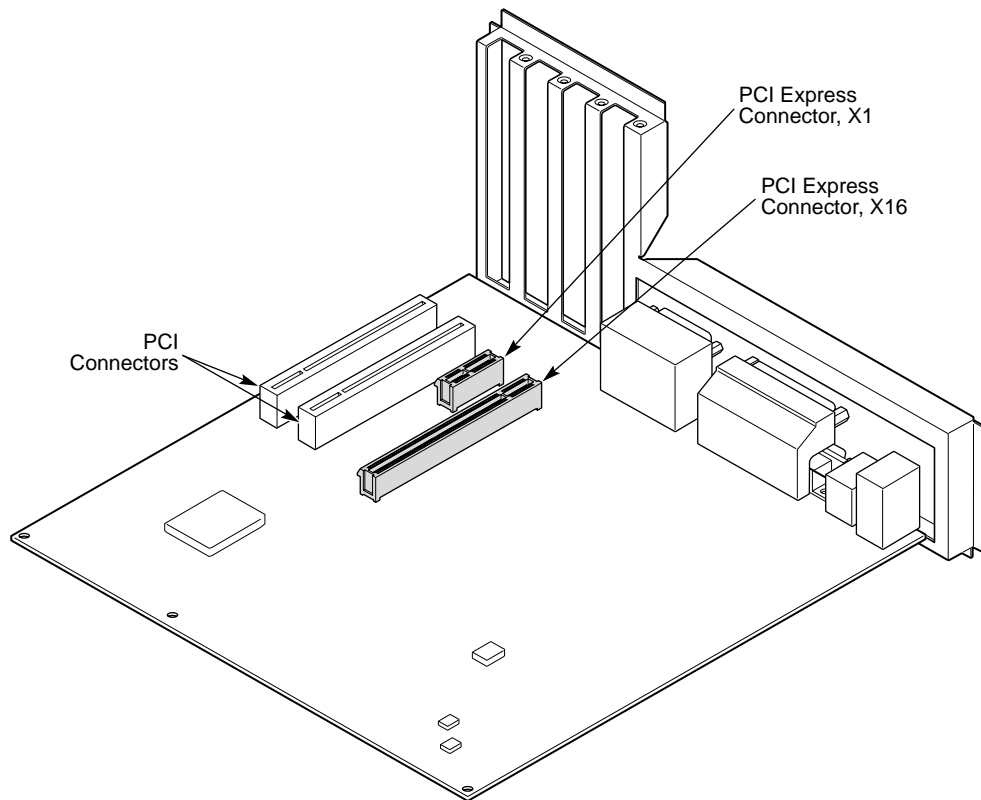

OM14766

Figure 4-2: PCI Express Connector on System Board with an Add-in Card

The topology of “PCI Express with two connectors on a riser card” allows for a plug-in PCI Express add-in card similar to a standard PCI or AGP add-in card to interface with a riser card using a PCI Express connector (Figure 4-3). The riser card plugs to the system board using another riser

5

connector (either PCI Express or other connector). In this topology, two connector-card interfaces exist.

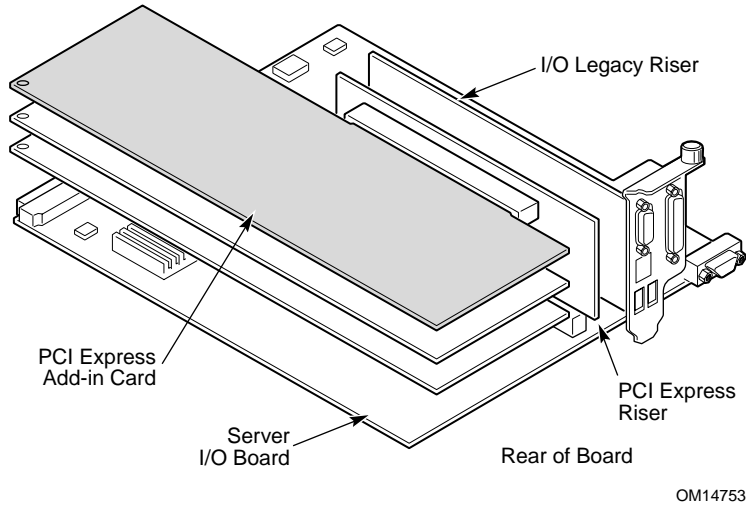

Figure 4-3: PCI Express Connector on a Riser Card with an Add-in Card

4.5.2. Link Definition

Typical PCI Express Links consist of the following:

- Transmitters/Receivers on an ASIC on a system board
- 5 Package fan-in-out trace topologies
- PCB coupled microstrip and/or striplines
- Vias for layer changes
- Optional proprietary PCI Express connector and riser card interface
- Optional riser card with microstrip and/or stripline trace
- 10 PCI Express connector and add-in card interface
- Coupled microstrip line and/or stripline traces on add-in card
- AC-coupling capacitors
- Transmitter/Receivers on an ASIC on the add-in card

The electrical parameters for the Link are subdivided into two components (Figure 4-4):

- 15 Add-in card
- System board and PCI Express connector (and riser card with associated connector if it exists)

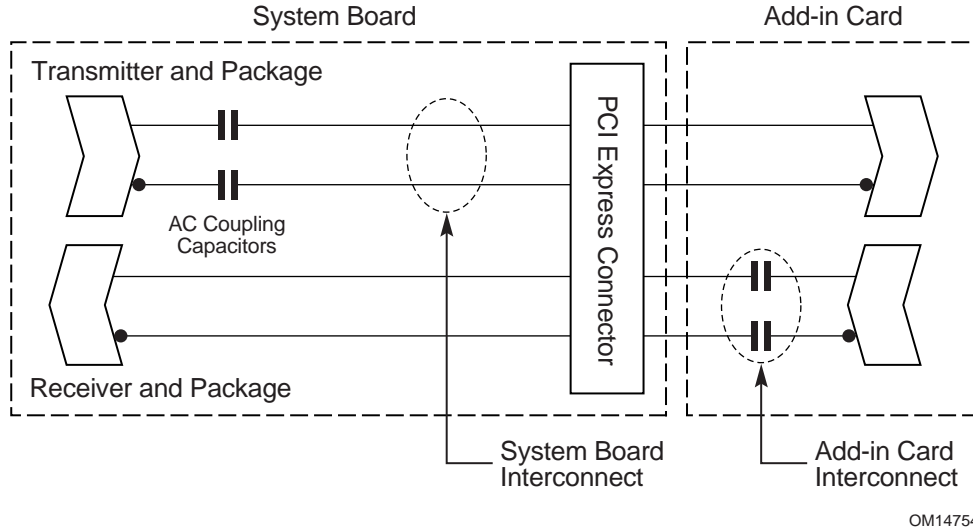

Figure 4-4: Link Definition for Two Components

The electrical impact of discontinuities on the Link such as via, bend, and test-points should be included in the respective components.

4.6. Electrical Budgets

A budget is defined for each of the following electrical parameters associated with the Link:

- AC coupling capacitors
- 5 Insertion Loss (Voltage Transfer Function)
- Jitter
- Lane-to-lane skew
- Crosstalk
- Equalization
- 10 Skew within a differential pair
- [Differential data trace impedance](#)
- [Differential data trace propagation delay](#)

The electrical budgets are different for each of the two Link components:

- Add-in card budget
- 15 System board and PCI Express connector budgets

The interconnect Link budget allocations associated with the Transmitters and Receivers differ. This is to account for any electrical characteristics the AC coupling capacitors may contribute to the Link.

4.6.1. AC Coupling Capacitors

The PCI Express add-in card and system board shall incorporate AC coupling capacitors on the Transmitter differential pair. This is to ensure blocking of the DC path between the PCI Express add-in card and the system board. The ~~suggested minimum 603-type (or smaller 402-type) capacitor with a value as~~ specific capacitance values are specified in the *PCI Express Base Specification, Revision 1.1*. ~~Any additional~~ 2.0. Note that attenuation or jitter caused by the coupling capacitors (~~other than 603-type~~) must be accounted for as part of the budget allocation for the physical interconnect component's path on which the capacitors are mounted. ~~The electrical budgets allocated for the AC coupling capacitors are defined in the following subsections. The allocated budget includes the electrical~~ Note that there may be parasitic effects associated with the component's placement as mounted on the printed circuit board.

4.6.2. Insertion Loss Values (Voltage Transfer Function)

The maximum loss values in dB (decibels) are specified for the system board and the add-in card. The insertion loss values are defined as the ratio of the voltage at the ASIC package pin (Transmitter/Receiver) and the voltage at the PCI Express connector interface, terminated by 100 Ω differential termination, realized as two 50 Ω resistances. These resistances are referenced to ground at the interface (see Figure 4-5).

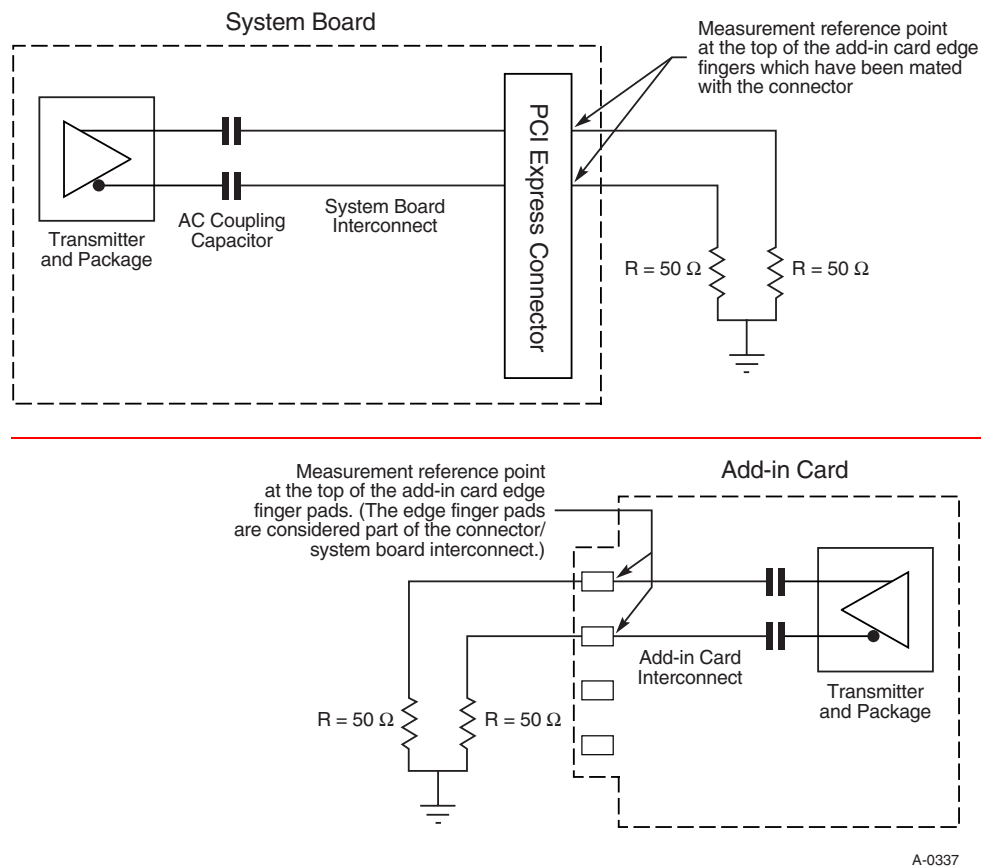

Figure 4-5: Example Interconnect Terminated at the Connector Interface

All PCI Express differential trace pairs are required to be referenced to the ground plane. The loss values associated with any riser card interface and adjoining connector implementation must collectively meet the system board loss budget allocations and associated eye diagrams.

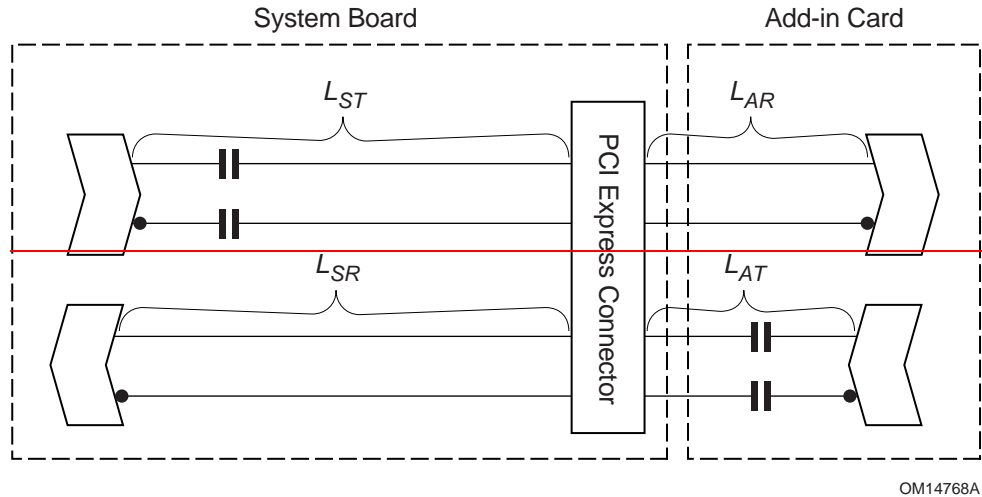

Figure 4-6: Insertion Loss Budgets

Table 4-3: Allocation of Interconnect Path Insertion Loss Budget

Loss Parameter	Loss Budget Value at 1.25 GHz (dB)		Loss Budget Value at 625 MHz (dB)		Comments
PCI Express Add-in Card	$L_{AR} < 2.65$	$L_{AT} < 3.84$	$L_{AR} < 1.95$	$L_{AT} < 2.94$	Notes 1, 2
System Board and Connector	$L_{ST} < 9.30$	$L_{SR} < 8.11$	$L_{ST} < 6.00$	$L_{SR} < 5.01$	Notes 1, 3
Guard Band	1.25		1.25		Note 4
Total Loss	$L_I < 13.2$		$L_I < 9.2$		

Notes:

All values are referenced to 100 Ω , realized as two 50 Ω resistances. The loss budget values include all possible crosstalk impacts (near end and far end) and potential mismatch of the actual interconnect with respect to the 100 Ω reference load.

The PCI Express Base Specification, Revision 1.1 allows an interconnect loss of 13.2 dB for 1.25 GHz (non de-emphasized) signals and 9.2 dB for 625 MHz (de-emphasized) signals. From this, a total of 1.25 dB is held in reserve as guard band to allow for any additional attenuation that might occur when the add-in card and system board are actually mated. The allocated loss budget values in the table directly correlate to the eye diagram voltages in Section 4.7. Tradeoffs in terms of attenuation, crosstalk, and mismatch can be made within the budget allocations specified.

As a guide for design and simulation, the following derivation of the budgets may be assumed for 1.25 GHz signals: 5.2 dB is subtracted from 13.2 dB to account for near end crosstalk and impedance mismatches. Out of this, the 1.25 dB is reserved as guard band. The following loss allocations are then assumed per differential pair: $L_{AR} = 1.4$ dB; $L_{AT} = 1.8$ dB; $L_{SR} = 6.2$ dB; $L_{ST} = 6.6$ dB. These allocation assumptions must also include any effects of far end crosstalk. 625 MHz values may be derived in a similar manner.

The add-in card budget does not include the add-in card edge finger or connector. However, it does include potential AC coupling capacitor attenuation on the Transmitter (TX) interconnect on add-in card. Note that the budget allocations generally allow for a maximum of 4-inch trace lengths for differential pairs having an approximate 5-mil trace width. No specific trace geometry, however, is explicitly defined in this specification. The subscripts of the symbol designators, T and R, represent the Transmitter and Receiver respectively.

The system board budget includes the PCI Express connector and assumes it is mated with the card edge finger. Refer to Section 5.3 for specifics on the standalone connector budget. The system board budget includes potential AC coupling capacitor attenuation on the Transmitter (TX) interconnect on the system board. The subscripts of the symbol designators, T and R, represent the Transmitter and Receiver respectively.

Note: The insertion loss budget distributions above are used to derive the eye diagram heights as described in Section 4.7. However, they are provided here only as a design guideline. Compliance measurements must actually be verified against the eye diagrams themselves as defined in Section 4.7.

[Appendix A contains background information on maximum insertion loss assumptions that were made in computing the 2.5 GT/s eye diagram requirements. This section is provided only for information purposes.](#)

4.6.3. Jitter Values

The maximum jitter values in terms of percentage of Unit Interval (UI = 400 ps for 2.5 GT/s and 200 ps for 5 GT/s) are specified for the system board and the add-in card. The jitter associated with the riser card and associated proprietary connector will be part of the system board jitter budget. The jitter values are defined with respect to 100 Ω differential termination, realized as two 50 Ω resistances. These resistances are referenced to ground at the interface (see Figure 4-7).

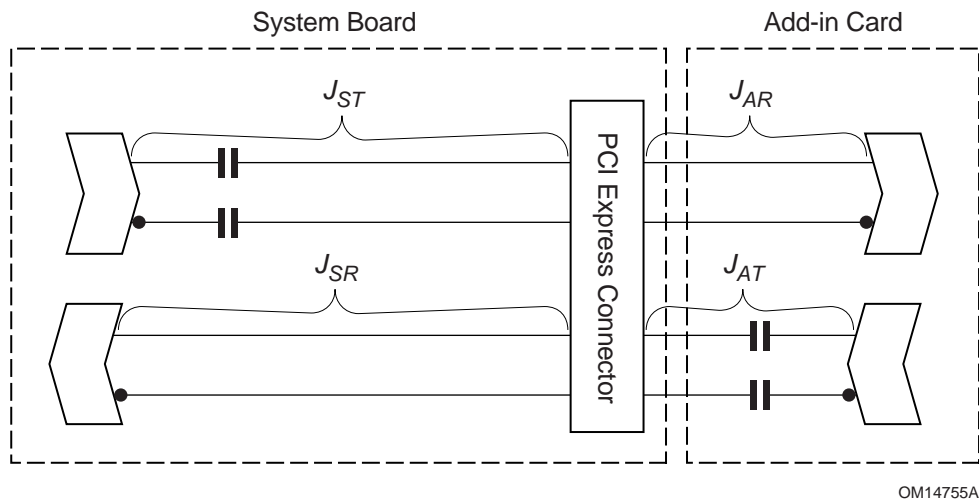

OM14755A

Figure 4-7: Jitter Budget

The total system jitter budget is derived with the assumption of a minimum R_j for each of the four budget items. This minimum R_j component is used to determine the overall system budget. The

probability distribution of the R_j component is at the Bit Error Rate (BER) indicated and is Gaussian.

For any jitter distribution the total T_j must always be met at the BER. The R_j of the components are independent and convolve as the root sum square. Tradeoffs of R_j and D_j are allowed, provided the total T_j is always met. More information on the calculation of the system budget can be found in *PCI Express Jitter and BER*.

Table 4-4: Total System Jitter Budget [For 2.5 GT/s Signaling](#)

Jitter Contribution	Min R _j (ps)	Max D _j (ps)	T _j at BER 10 ⁻¹² (ps) ³	T _j at BER 10 ⁻⁶ (ps)
Tx	2.8	60.6	100	87
Ref Clock	4.7	41.9	108	86
Media	0	90	90	90
Rx	2.8	120.6	160	147
Linear Total T_j:			458	410
Root Sum Square (RSS) Total T_j:			399.13	371.52

Notes:

- RSS equation for BER 10⁻¹² T_j = $\sum D_{j_n} + 14.069 * \sqrt{\sum R_{j_n}^2}$
- RSS equation for BER 10⁻⁶ T_j = $\sum D_{j_n} + 9.507 * \sqrt{\sum R_{j_n}^2}$

Table 4-5: Allocation of Interconnect Jitter Budget [For 2.5 GT/s Signaling](#)

Jitter Parameter	Jitter Budget Value (UI)		Comments
PCI Express Add-in Card	$J_{AR} < 0.0575$	$J_{AT} < 0.0650$	Notes 1, 2
System Board and Connector	$J_{ST} < 0.1675$	$J_{SR} < 0.1600$	Notes 1, 3
Total Jitter	$J_T < 0.225$		Note 1

Notes:

- All values are referenced to 100 Ω, realized as two 50 Ω resistances. The jitter budget values include all possible crosstalk impacts (near-end and far-end) and potential mismatch of the actual interconnect with respect to the 100 Ω reference load.

The *PCI Express Base Specification, Revision [4.42.0](#)* allows an interconnect jitter budget of 0.225 UI (equivalent to 90 ps for a 400 ps Unit-Interval). The allocated jitter budget values in Table 4-4 and [Table 4-5](#) directly correlate to the eye diagram widths in Section 4.7. Tradeoffs in terms of attenuation, crosstalk, and mismatch can be made within the budget allocations specified. No additional guard band is specifically allocated.

³ This column provides jitter limits at different BER values on a bathtub curve. If bathtub curves are not used in jitter measurements, then the jitter limit in the 10⁻⁶ column should be used as the total jitter limit for measurements using approximately 10⁶ unit intervals of data.

The jitter allocations are then assumed per differential pair according to the table. These allocation assumptions must also include any effects of far-end crosstalk.

2. All values are referenced to 100 Ω. The add-in card budget does not include the add-in card edge finger or connector. However, it does include potential jitter from the AC coupling capacitors on the Transmitter (TX) interconnect of the add-in card. The budget allocations generally allow for a maximum of 4-inch trace lengths for differential pairs having an approximate .127-mm (5-mil) trace width. No specific trace geometry, however, is explicitly defined in this specification. The subscripts of the symbol designators, T and R, represent the Transmitter and Receiver respectively.
3. All values are referenced to 100 Ω. The system board budget includes the PCI Express connector and assumes it is mated with the card edge finger. Refer to Section 5.3 for specifics on the standalone connector budget. The system board budget includes potential jitter from the AC coupling capacitors on the Transmitter (TX) interconnect on the system board. The subscripts of the symbol designators, T and R, represent the Transmitter and Receiver respectively.

The total system jitter budget for 5 GT/s signaling specifies separate RJ and DJ limits for each of the four components in the jitter budget. Refer to Section 4.3.2 in the *PCI Express Base Specification, Revision 2.0* for a more detailed discussion of the system jitter budget, RJ and DJ.

Table 4-6: Total System Jitter Budget For 5 GT/s Signaling

<u>Jitter Contribution</u>	<u>Max Dj (ps)</u>	<u>Tj at BER 10⁻¹² (ps)</u>
<u>Tx</u>	<u>30</u>	<u>50</u>
<u>Ref Clock</u>	<u>0</u>	<u>43.6</u>
<u>Media</u>	<u>58</u>	<u>58</u>
<u>Rx</u>	<u>60</u>	<u>80</u>
<u>Linear Total Tj:</u>		<u>231.6</u>
<u>Root Sum Square (RSS) Total Tj:</u>		<u>200</u>

Notes:

1. RSS equation for BER 10⁻¹² Tj = $\sum Dj_n + 14.069 * \sqrt{\sum Rj_n^2}$

Note: The jitter budget distributions above are used to derive the eye diagram widths as described later in this chapter. However, they are provided here only as a design guideline. Compliance measurements must actually be verified against the eye diagrams themselves as defined in Section 4.7.

4.6.4. Crosstalk

All add-in card designs must properly account for any crosstalk that may exist among the various pairs of differential signals. Crosstalk may be either near-end (NEXT) or far-end (FEXT). Each component can have potential impact on a design and must be planned for accordingly.

Note that the total maximum crosstalk that a Receiver component in Electrical Idle is required to tolerate is < 65 mV as dictated by the Electrical Idle Detect Threshold in the *PCI Express Base Specification, Revision ~~4.1~~2.0*. Additionally, crosstalk between differential pairs on the add-in card will

influence and impact the data signals and any subsequent loss and jitter budgets as noted in Sections 4.6.2 and 4.6.3. Note that all eye diagrams in Section 4.7 must account for any and all crosstalk present. In order to limit crosstalk impacts and implications, it is recommended that the add-in card limit the total amount of NEXT to a maximum of 50 mV.

- 5 All system boards interfacing with an add-in card must also properly account for crosstalk. The system board must also account for potential crosstalk that can occur on the printed circuit board as well as within the connector itself (see Section 5.3).

4.6.5. Lane-to-Lane Skew

10 The skew at any point is measured using zero crossings of differential voltage of the compliance pattern, while simultaneously transmitting on all physical Lanes. The compliance pattern is defined in the *PCI Express Base Specification, Revision ~~4.1~~2.0*.

Table 4-7: Allowable Interconnect Lane-to-Lane Skew

Skew Parameter	Symbol	Skew Values	Comments
Total Interconnect Skew	S_T	1.6 ns	This does not include Transmitter output skew, $L_{TX-SKEW}$ (specified in the <i>PCI Express Base Specification, Revision 4.12.0</i>). The total skew at the Receiver ($S_T + L_{TX-SKEW}$) is smaller than $L_{RX-SKEW}$ (specified in the <i>PCI Express Base Specification, Revision 4.12.0</i>) to minimize latency for this add-in card topology.
PCI Express Add-in Card	S_A	0.35 ns	Estimates about a 2-inch trace length delta on FR4 boards.
System Board	S_s	1.25 ns	Estimates about a 7-inch trace length delta on FR4 boards.

4.6.6. Equalization

15 To reduce ISI, 3.5 dB (~~+/-(±0.5 dB)~~) below the first bit de-emphasis in the Transmitter is required for the add-in card and the system board for 2.5 GT/s signaling: 6.0 dB (±.5 dB) or 3.5 dB (±0.5 dB) de-emphasis is required for the add-in card and system board for 5 GT/s signaling. For implementation details, refer to Chapter 4 in the *PCI Express Base Specification, Revision ~~4.1~~2.0*.

4.6.7. Skew within the Differential Pair

The skew within the differential pair gives rise to a common-mode signal component, which can, in turn, increase Electromagnetic Interference (EMI). The differential pair ~~should~~ shall be routed such that the skew within differential pairs is less than .127 mm (5 mils) for the add-in card and .254 mm (10 mils) for the system board.

4.6.8. Differential Data Trace Impedance

The PCB trace pair differential impedance for a 5 GT/s capable data pair must be in the range of 68 Ω to 105 Ω . This applies to both the add-in card and the system board.

Note: This requirement does not apply to vias, the connectors, package traces, cables, and other similar structures.

Note: Designs should still attempt to minimize the impedance discontinuities from vias, the connectors, package traces, cables, and other similar structures.



IMPLEMENTATION NOTE

Differential PCB Trace Impedance

The PCB trace impedance requirement specified in Section 4.6.8 only applies to topologies that support 5 GT/s covered by this form factor specification that use the connector defined in this form factor specification.

Specifically, the *PCI Express Card Electromechanical Specification* covers the following two topologies (as defined in Section 4.5.1):

- PCI Express devices across one card electromechanical connector on a system with a system board and an add-in card
- PCI Express devices across two card electromechanical connectors on a system with a system board, a riser card, and an add-in card, where the connector between the riser card and the add-in card is a card electromechanical connector.

Other topologies governed by different specifications may impose different impedance requirements or leave the impedance unspecified.

For example, the topology of "PCI Express devices on the same system board" does not fit within a form factor specification and hence must only follow the requirements of the *PCI Express Base Specification*. The *PCI Express Base Specification* does not define a PCB trace impedance requirement so with this topology designers can choose the PCB trace impedance that is best for their applications.

4.6.9. Differential Data Trace Propagation Delay

The propagation delay for an add-in card data trace from the edge finger to the Receiver/Transmitter must not exceed 750 ps.

4.7. Eye Diagrams at the Add-in Card Interface

The eye diagrams defined in this section represent the compliance eye diagrams that must be met for both the add-in card and a system board interfacing with such an add-in card. The specific measurement requirements (probe test points, calibrated system board specifics, etc.) for compliance of physical components are to be specified in the *PHY Electrical Test Considerations for PCI Express Architecture* document. A sample size of 10^6 UI is assumed for the eye diagram measurements. These compliance eye diagrams with BER of 10^{-12} can also be used for simulation by following the guidelines explained in Section 4.6.

~~Add-in Card Transmitter Path Compliance Eye Diagram~~

Note: The eye ~~diagram for the add-in card's Transmitter path compliance~~ diagrams specified for 5 GT/s include de-emphasis jitter affects. De-emphasis jitter is not derated in 5 GT/s measurements.

4.7.1. Add-in Card Transmitter Path Compliance Eye Diagram at 2.5 GT/s

The eye diagrams for the add-in card's Transmitter path compliance at 2.5 GT/s are defined in Table 4-8 and [Figure 4-9](#).

Table 4-8: Add-in Card Transmitter Path Compliance Eye Requirements at 2.5 GT/s

Parameter	Value	Comments
V_{TXA}	≥ 514 mV	Notes 1, 2, 5
V_{TXA_d}	≥ 360 mV	Notes 1, 2, 5
T_{TXA}	≥ 287 ps	Notes 1, 3, 5
$J_{TXA-MEDIAN-to-MAX-JITTER}$	≤ 56.5 ps	Notes 1, 4, 5

<u>Parameter</u>	<u>Min</u>	<u>Max</u>	<u>Unit</u>	<u>Comments</u>
V_{TXA}	514	1200	mV	Notes 1, 2, 5
V_{TXA_d}	360	1200	mV	Notes 1, 2, 5
T_{TXA}	287		ps	Notes 1, 3, 5
$J_{TXA-MEDIAN-to-MAX-JITTER}$		56.5	ps	Notes 1, 4, 5

Notes: _____

- An ideal reference clock without jitter is assumed for this specification. All Links are assumed active while generating this eye diagram.
- Transition and non-transition bits must be distinguished in order to measure compliance against the de-emphasized voltage level (V_{TXA_d}). V_{TXA} and V_{TXA_d} are minimum differential peak-peak output voltages.
- T_{TXA} is the minimum eye width. The sample size for this measurement is 10^6 UI. This value can be reduced to 274 ps for simulation purpose at BER 10^{-12} .

4. $J_{TXA-MEDIAN-to-MAX-JITTER}$ is the maximum median-to-max jitter outlier as defined in the *PCI Express Base Specification, Revision 4.2.0*. The sample size for this measurement is 10^6 UI. This value can be increased to 63 ps for simulation purpose at BER 10^{-12} .
5. The values in Table 4-8 are referenced to an ideal $100\ \Omega$ differential load at the end of the interconnect path at the edge-finger boundary on the add-in card (see Figure 4-7). The eye diagram is defined and centered with respect to the jitter median. Exact conditions required for verifying compliance while generating this eye diagram are given in the *PHY Electrical Test Considerations for PCI Express Architecture* document.

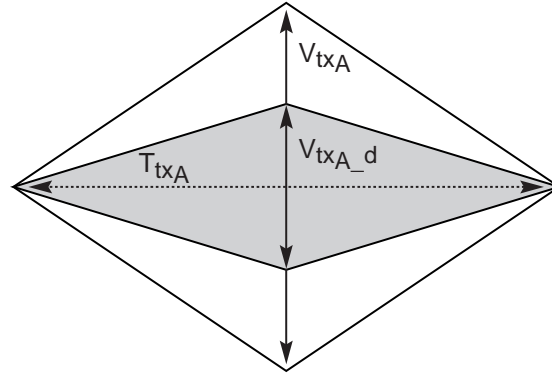

OM14758A

Figure 4-8: Add-in Card Transmitter Path Compliance Eye Diagram

Add-in Card ~~Minimum Receiver~~ Transmitter Path ~~Sensitivity~~ Requirements

4.7.2. Compliance Eye Diagrams at 5 GT/s

The ~~minimum sensitivity values~~ eye diagrams for the add-in card's ~~Receiver~~ Transmitter path compliance at 5 GT/s are defined in Table 4-8 ~~and a representative eye diagram is shown in Figure 4-9,~~ Table 4-9, Table 4-10, Table 4-11, Table 4-12, and Figure 4-9.

Table 4-9: Add-in Card Transmitter Path Compliance Eye Requirements at 5 GT/s and 3.5 dB De-emphasis

<u>Parameter</u>	<u>Min</u>	<u>Max</u>	<u>Unit</u>	<u>Comments</u>
<u>V_{TXA}</u>	<u>380</u>	<u>1200</u>	<u>mV</u>	<u>Notes 1, 2, 4</u>
<u>V_{TXA_d}</u>	<u>380</u>	<u>1200</u>	<u>mV</u>	<u>Notes 1, 2, 4</u>
<u>T_{TXA} (with crosstalk)</u>	<u>123</u>		<u>ps</u>	<u>Notes 1, 3, 4</u>
<u>T_{TXA} (without crosstalk)</u>	<u>126</u>		<u>ps</u>	

Notes:

1. An ideal reference clock without jitter is assumed for this specification. All Links are assumed active while generating this eye diagram. The eye diagram

requires that CMM pattern (PCI Express Base Specification, Revision 2.0, Section 4.2.8) is being transmitted during the test.

2. Transition and non-transition bits must be distinguished in order to measure compliance against the de-emphasized voltage level ($V_{TXA,d}$). V_{TXA} and $V_{TXA,d}$ are minimum differential peak-peak output voltages.
3. T_{TXA} is the minimum eye width. The recommended sample size for this measurement is at least 10^6 UI. This calculated eye width at BER 10^{-12} must not exceed T_{TXA} . If the add-in card board uses non-interleaved routing, then crosstalk will be present in the measured data. If the add-in card board uses interleaved routing, then crosstalk will not be present and an adjusted minimum eye width is used.
4. The values in Table 4-9 are referenced to an ideal 100 Ω differential load at the end of an isolated 3-inch long 85 Ω differential trace behind a standard PCI Express connector. Exact conditions required for verifying compliance while generating this eye diagram are given in the *PHY Electrical Test Considerations for PCI Express Architecture* document.

The add-in card total jitter for the Transmitter + Transmitter interconnect must meet the requirements in Table 4-10 when decomposed into random and deterministic jitter.

Table 4-10: Add-in Card Jitter Requirements For 5 GT/s Signaling at 3.5 dB De-emphasis

	<u>Max Dj (ps)</u>	<u>Tj at BER 10^{-12} (ps)</u>
<u>With crosstalk</u>	<u>57</u>	<u>77</u>
<u>Without crosstalk</u>	<u>54</u>	<u>74</u>

Table 4-11: Add-in Card Transmitter Path Compliance Eye Requirements at 5 GT/s at 6.0 dB De-emphasis

<u>Parameter</u>	<u>Min</u>	<u>Max</u>	<u>Unit</u>	<u>Comments</u>
<u>V_{TXA}</u>	<u>306</u>	<u>1200</u>	<u>mV</u>	<u>Notes 1, 2, 4</u>
<u>$V_{TXA,d}$</u>	<u>260</u>	<u>1200</u>	<u>mV</u>	<u>Notes 1, 2, 4</u>
<u>T_{TXA} (With crosstalk)</u>	<u>123</u>		<u>ps</u>	<u>Notes 1, 3, 4</u>
<u>T_{TXA} (Without crosstalk)</u>	<u>126</u>		<u>ps</u>	

Notes:

1. An ideal reference clock without jitter is assumed for this specification. All Links are assumed active while generating this eye diagram. The eye diagram requires that CMM pattern (PCI Express Base Specification, Revision 2.0, Section 4.2.8) is being transmitted during the test.
2. Transition and non-transition bits must be distinguished in order to measure compliance against the de-emphasized voltage level ($V_{TXA,d}$). V_{TXA} and $V_{TXA,d}$ are minimum differential peak-peak output voltages.
3. T_{TXA} is the minimum eye width. The recommended sample size for this measurement is at least 10^6 UI. This calculated eye width at BER 10^{-12} must not exceed T_{TXA} . If the add-in card board uses non-interleaved routing, then crosstalk will be present in the measured data. If the add-in card board uses interleaved routing, then crosstalk will not be present and an adjusted minimum eye width is used.

- 5
4. The values in Table 4_11 are referenced to an ideal 100 Ω differential load at the end of an isolated 3-inch long 85 Ω differential trace behind a standard PCI Express connector. Exact conditions required for verifying compliance while generating this eye diagram are given in the *PHY Electrical Test Considerations for PCI Express Architecture* document.

The add-in card total jitter for the Transmitter + Transmitter interconnect must meet the requirements in Table 4_12 when decomposed into random and deterministic jitter.

Table 4-12: Add-in Card Jitter Requirements For 5 GT/s Signaling at 6.0 dB De-emphasis

	Max Dj (ps)	Tj at BER 10⁻¹² (ps)
<u>With crosstalk</u>	<u>57</u>	<u>77</u>
<u>Without crosstalk</u>	<u>54</u>	<u>74</u>

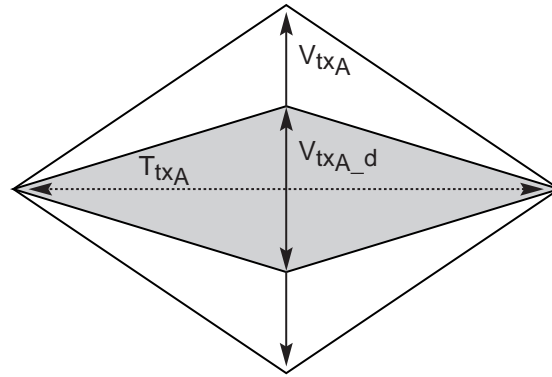

OM14758A

Figure 4-9: Add-in Card Transmitter Path Compliance Eye Diagram

4.7.3. Add-in Card Minimum Receiver Path Sensitivity Requirements at 2.5 GT/s

The minimum sensitivity values for the add-in card’s Receiver path compliance at 2.5 GT/s are defined in Table 4-13, and a representative eye diagram is shown in Figure 4-11.

Table 4-13: Add-in Card Minimum Receiver Path Sensitivity Requirements at 2.5 GT/s

Parameter	Value	Comments
V_{RXA}	238 mV	Notes 1, 2, 5
V_{RXA_d}	219 mV	Notes 1, 2, 5
T_{RXA}	246 ps	Notes 1, 3, 5
$J_{RXA-MEDIAN-to-MAX-JITTER}$	77 ps	Notes 1, 4, 5

<u>Parameter</u>	<u>Min</u>	<u>Max</u>	<u>Unit</u>	<u>Comments</u>
V_{RXA}	238	1200	mV	Notes 1, 2, 5
V_{RXA_d}	219	1200	mV	Notes 1, 2, 5
T_{RXA}	246		ps	Notes 1, 3, 5
$J_{RXA-MEDIAN-to-MAX-JITTER}$	77		ps	Notes 1, 4, 5

Notes:

1. An ideal reference clock without jitter is assumed for this specification. All Links are assumed active while generating this eye diagram.

2. Transition and non-transition bits must be distinguished in order to measure compliance against the de-emphasized voltage level (V_{RXA_d}). V_{RXA} and V_{RXA_d} are differential peak-peak output voltages.
3. T_{RXA} is the eye width. The sample size for this measurement is 10^6 UI. This value can be reduced to 233 ps for simulation purpose at BER 10^{-12} .
4. $J_{RXA_MEDIAN-10-MAX-JITTER}$ is the maximum median-to-peak jitter outlier as defined in the *PCI Express Base Specification, Revision 4.12.0*. The sample size for this measurement is 10^6 UI. This value can be increased to 83.5 ps for simulation purpose at BER 10^{-12} .
5. The values in [Table 4-13](#) are initially referenced to an ideal 100 Ω differential load. The resultant values, when provided to the Receiver interconnect path of the add-in card, allow for a demonstration of compliance of the overall add-in card Receiver path. The sensitivity requirements are defined and centered with respect to the jitter median. Exact conditions required for verifying compliance against these values are given in the *PHY Electrical Test Considerations for PCI Express Architecture* document.

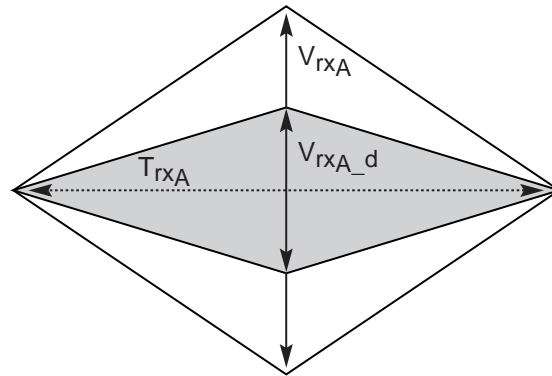

OM14759A

Figure 4-10: Representative Composite Eye Diagram for Add-in Card Receiver Path Compliance

4.7.4. Add-in Card Minimum Receiver Path Sensitivity Requirements at 5 GT/s

The minimum sensitivity values for the add-in card's Receiver path compliance at 5 GT/s are defined in Table 4-14, and a representative eye diagram is shown in Figure 4-11.

Table 4-14: Add-in Card Minimum Receiver Path Sensitivity Requirements at 5 GT/s

<u>Parameter</u>	<u>Min</u>	<u>Max</u>	<u>Unit</u>	<u>Comments</u>
<u>V_{RXA}</u>	<u>300</u>	<u>1200</u>	<u>mV</u>	<u>Notes 1, 2, 3</u>
<u>V_{RXA,d}</u>	<u>300</u>	<u>1200</u>	<u>mV</u>	<u>Notes 1, 2, 3</u>
<u>1.5 – 100 MHz RMS Jitter</u>	<u>3.4</u>		<u>ps RMS</u>	
<u>33 kHz Refclk Residual</u>	<u>75</u>		<u>ps PP</u>	
<u>< 1.5 MHz RMS Jitter</u>	<u>4.2</u>		<u>ps RMS</u>	
<u>1.5 – 100 MHz DJ</u>	<u>30</u>		<u>ps PP</u>	
<u>> 100 MHz DJ</u>	<u>27</u>		<u>ps PP</u>	

Notes:

- An ideal reference clock without jitter is assumed for this specification. All Links are assumed active while generating this eye diagram. The CMM pattern must be transmitted during the test.
- Transition and non-transition bits must be distinguished in order to measure compliance against the de-emphasized voltage level (V_{RXA,d}). V_{RXA} and V_{RXA,d} are differential peak-peak output voltages.
- The values in Table 4-14 are initially referenced to an ideal 100 Ω differential load behind 2 inches of isolated 85 Ω trace and a standard PCI Express edge finger. After reference calibration, the reference fixture is removed and the add-in card to be tested is placed into a standard PCI Express connector. The resultant values, when provided to the Receiver interconnect path of the add-in card, allow for a demonstration of compliance of the overall add-in card Receiver path. The exact setup and methodology for injecting this signal into the Receiver interconnect path of the add-in card are not specified. The values in Table 4-13 may need to be adjusted based on the exact test setup and methodology. For example, if the impedance of the test setup does not create the worst case mismatch that could be present with a real system board or the test setup does not provide crosstalk (only a single Lane is tested, etc) the values in Table 4-13 must be adjusted accordingly.

5
10
15
20

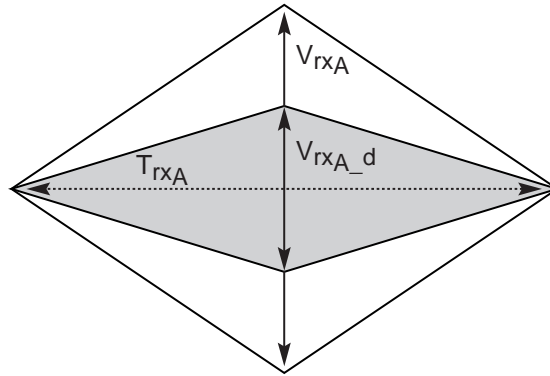

OM14759A

Figure 4-11: Representative Composite Eye Diagram for Add-in Card Receiver Path Compliance

4.7.5. System Board Transmitter Path Compliance Eye Diagram [at 2.5 GT/s](#)

The eye diagram for the system board's Transmitter compliance [at 2.5 GT/s](#) is defined in Table 4-15 and ~~in~~ [Figure 4-14](#).

Table 4-15: System Board Transmitter Path Compliance Eye Requirements [at 2.5 GT/s](#)

Parameter	Value		Comments
V_{TXS}	≥ -274 mV		Notes 1, 2, 5
V_{TXS_d}	≥ -253 mV		Notes 1, 2, 5
T_{TXS}	≥ -246 ps		Notes 1, 3, 5
$J_{TXS-MEDIAN-to-MAX-JITTER}$	≤ -77 ps		Notes 1, 4, 5

Parameter	Min	Max	Unit	Comments
V_{TXS}	274	1200	mV	Notes 1, 2, 5
V_{TXS_d}	253	1200	mV	Notes 1, 2, 5
T_{TXS}	246		ps	Notes 1, 3, 5
$J_{TXS-MEDIAN-to-MAX-JITTER}$		77	ps	Notes 1, 4, 5

Notes:

1. An ideal reference clock without jitter is assumed for this specification. All Links are assumed active while generating this eye diagram.
2. Transition and non-transition bits must be distinguished in order to measure compliance against the de-emphasized voltage level (V_{TXS_d}). V_{TXS} and V_{TXS_d} are minimum differential peak-peak output voltages.
3. T_{TXS} is the minimum eye width. The sample size for this measurement is 10^6 UI. This value can be reduced to 233 ps for simulation purpose at BER 10^{-12} .

5

10

4. $J_{\text{TXS-MEDIAN-to-MAX-JITTER}}$ is the maximum median-to-max jitter outlier as defined in *the PCI Express Base Specification, Revision 4.12.0*. The sample size for this measurement is $40^6 \cdot 10^6 UI_T$. This value can be increased to 83.5 ps for simulation purpose at BER 10^{-12} .
5. The values in Table 4-15 are referenced to an ideal 100 Ω differential load at the end of the interconnect path at the edge-finger boundary on the add-in card when mated with a connector (see Figure 4-7). The eye diagram is defined and centered with respect to the jitter median. Exact conditions required for verifying compliance while generating this eye diagram are given in the *PHY Electrical Test Considerations for PCI Express Architecture* document.

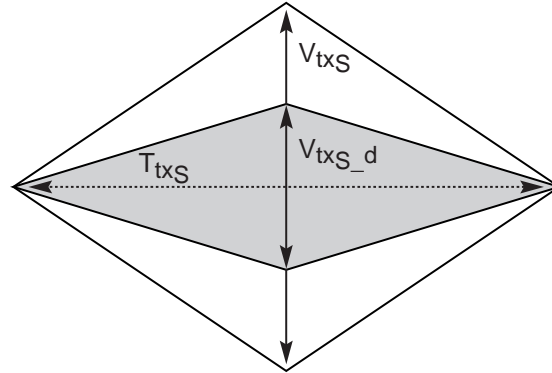

A-0335

Figure 4-12: System Board Transmitter Path Composite Compliance Eye Diagram

~~It is not always possible to measure the System Board Transmitter Path Eye Diagrams with an ideal reference clock. In this case, a two port measurement can adjust the measurement for the non-ideal reference clock. The notation in this section assumes the discrete time domain form of x_n . Equivalent notation sometimes used in other literature is $x(n)$ and $x[n]$. The convolution operator is denoted as \otimes .~~

4.7.6. ~~Referring to~~ System Board Transmitter Path Compliance Eye Diagram at 5 GT/s

The system board Transmitter path measurements at 5 GT/s are made using a two port measurement methodology. Figure 4-13;

~~x_n is the sampled phase jitter on the reference clock at the connector. A band-pass function is used to measure the reference clock as described in Section 2.1.~~

~~h_n is the impulse response of the transmitter PLL on the system board.~~

~~n_n is the intrinsic transmitter jitter. Using an ideal reference clock with 0 phase jitter, this would be the measured transmitter jitter. The peak-peak value of the total jitter must meet the eye requirements as specified in the *PCI Express Base Specification*.~~

~~$y_n = [x_n \otimes h_n] + n_n$ is the total jitter of the reference clock, transmitter and system board interconnect at the connector, where \otimes is the discrete convolution operator.~~

~~In the case of non-zero reference clock noise, the intrinsic jitter of the transmitter can be calculated in the discrete time domain by the following:~~

$$n_n = y_n - [x_n \otimes h_n]$$

where x_n is convolved with h_n . The peak-peak value of n_n is then calculated.

The equation above has two unknowns, h_n and n_n . If h_n is known, it can be used directly. Otherwise, h_n must be assumed to be the lowest limit of the allowed PLL bandwidth with no peaking (see the *PCI Express Base Specification* for the specification limits).

A summary of this procedure is as follows:

Take the simultaneous measurements of y_n and x_n for the system board at the connector.

Find $x_n \otimes h_n$.

Calculate $n_n = y_n - [x_n \otimes h_n]$.

Calculate the peak-peak value of n_n .

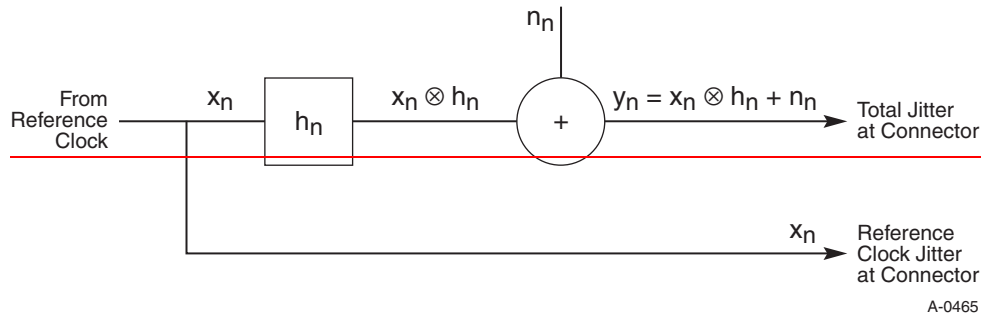

Figure shows a functional block diagram for a system board and add-in card that shows the measurement points for the two port method.

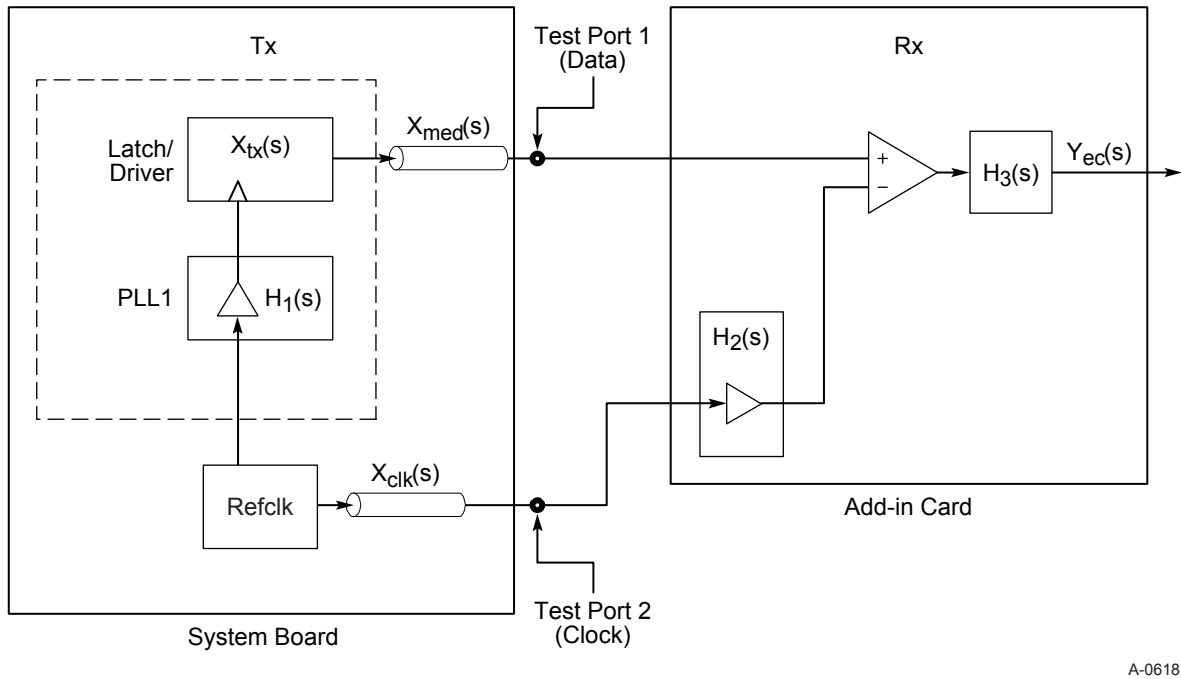

Figure 4-13: Two-Port Measurement Model

System Board Minimum Receiver Path Sensitivity Requirements

The minimum sensitivity values for the system board's Receiver path compliance are defined in Table 4-10 and a representative eye diagram is shown in Figure 4-12.

Table 4-10: System Board Minimum Receiver Path Sensitivity Requirements

Parameter	Value	Comments
V_{RXS}	445 mV	Notes 1, 2, 5
V_{RXS_d}	312 mV	Notes 1, 2, 5
T_{RXS}	287 ps	Notes 1, 3, 5
$J_{RXS-MEDIAN-to-MAX-JITTER}$	56.5 ps	Notes 1, 4, 5

: Two Port Measurement Functional Block Diagram

- 5 Equations for the jitter at test port 1 and test port 2 and the eye closure at the add-in card Receiver from the test port signals are provided as follows:

Data Port Measurement (Test Port 1):

$$\text{Eq.(1)} \quad X_{dm}(s) = X_{clk}(s)H_1(s)e^{-sT_{d1a}} + X_{tx}(s) + X_{med}(s)$$

Clock Port Measurement (Test Port 2):

10
$$\text{Eq.(2)} \quad X_{cm}(s) = X_{clk}(s)e^{-sT_{d1b}}$$

Eye Closure At Receiver Due to Signals At Clock and Data Ports:

$$\begin{aligned} \text{Eq.(3)} \quad Y_{ec}(s) &= \{ [X_{clk}(s)H_1(s)e^{-sT_{d1a}} + X_{tx}(s) + X_{med}(s)] - [X_{clk}(s)e^{-sT_{d1b}}][H_2(s)e^{-sT_{d2}}] \} \bullet H_3(s) \\ &= (X_{dm}(s) - X_{clk}(s)H_2(s)e^{-sT_{d2}}) \bullet H_3(s) \end{aligned}$$

- 15 Where $X_{clk}(s)$ is the reference clock transfer function, T_{d1a} is the delay from the reference clock to the data port, T_{d1b} is the delay from the reference clock to the test port, $X_{tx}(s)$ is the driver/latch transfer function, and $X_{med}(s)$ is the interconnect transfer function. Where the RX PLL transfer function $H_2(s)$, and PI transfer function $H_3(s)$ are the same as those defined in the *PCI Express Base Specification, Revision 2.0* with parameters that give rise to the largest eye closure $Y_{ec}(s)$. The delay T_{d2} is swept from -3 ns to 3 ns – consistent with the maximum transport delay that can occur in the add-in card.
- 20

The two port measurement methodology is performed according to the following steps:

- ❑ Data is gathered from test port 1 and test port 2 to obtain the spectrum $X_{dm}(s)$ and $X_{cm}(s)$ or equivalent.
- ❑ The eye closure $Y_{ec}(s)$ or $Y_{ec}(t)$ is calculated based on equation 3. T_{d2} is swept from -3 ns to 3 ns. $H_2(s)$ is defined in Figure 4-21 of the *PCI Express Base Specification, Revision 2.0*. $H_2(s)$ is one of the following values:

$$H_2(s) = \frac{2\zeta\omega_{n2}s + \omega_{n2}^2}{s^2 + 2\zeta\omega_{n2}s + \omega_{n2}^2}$$

where: $\zeta = 0.54$ (3 dB PK), $\omega_{n2} = 8.61 * 2\pi$ (16MHz 3dB BW) Mrad / s or

$\zeta = 0.54$ (3 dB PK), $\omega_{n2} = 4.31 * 2\pi$ (8 Mhz, 3dB BW) Mrad / s or

$\zeta = 1.16$ (1 dB PK), $\omega_{n2} = 1.82 * 2\pi$ (5 MHz 3dB BW) Mrad / s

- ❑ Calculate the eye closure at BER= 10^{-12} based on $Y_{ec}(t)$. The maximum eye closure for any parameters of T_{d2} and $H_2(s)$ in the defined ranges is the total jitter assigned to the system board Transmitter + Transmitter interconnect + reference clock.

Table 4-17: System Board Transmitter Path Compliance Eye Requirements at 5 GT/s

Parameter	Min	Max	Unit	Comments
V_{TXS}	300	1200	mV	Notes 1, 2, 4
V_{TXS_d}	300	1200		Notes 1, 2, 4
T_{TXS} (with crosstalk)	95		ps	Notes 1, 3, 4
T_{TXS} (without crosstalk)	108		ps	

Notes:

1. All Links are assumed active while generating this eye diagram. The eye diagram requires that CMM pattern (*PCI Express Base Specification, Revision 2.0, Section 4.2.8*) is being transmitted during the test using the de-emphasis level that the system board will use in normal operation.
2. Transition and non-transition bits must be distinguished in order to measure compliance against the de-emphasized voltage level (V_{TXS_d}). V_{TXS} and V_{TXS_d} are minimum differential peak-peak output voltages.
3. T_{TXS} is the minimum eye width. The recommended sample size for the dual port measurement is at least 10^6 UI. The minimum eye opening at BER 10^{-12} is calculated based on the measured data and must not exceed T_{TXS} . If the system board uses non-interleaved routing, then crosstalk will be present in the measured data. If the system uses interleaved routing, then crosstalk will not be present and an adjusted minimum eye width is used.
4. The values in Table 4-17 are referenced to an ideal 100 Ω differential load at the end of an isolated 2-inch 85 Ω differential trace behind a standard PCI express edge finger. Exact conditions required for verifying compliance while generating this eye diagram are given in the *PHY Electrical Test Considerations for PCI Express Architecture* document.

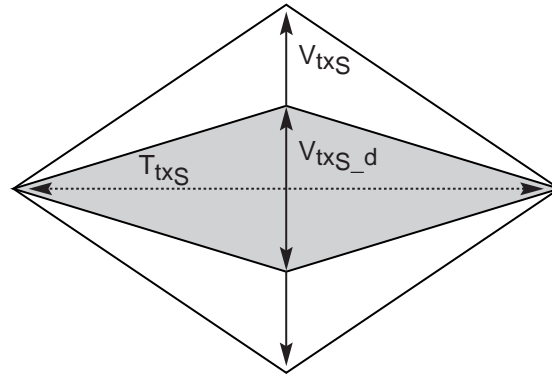

A-0335

Figure 4-14: System Board Transmitter Path Composite Compliance Eye Diagram

The system board total jitter for the Transmitter + Transmitter interconnect + reference clock must meet the requirements in Table 4-18 when decomposed into random and deterministic jitter.

Table 4-18: System Board Jitter Requirements For 5 GT/s Signaling

	Max Dj (ps)	Tj at BER 10 ⁻¹² (ps)
With crosstalk	57	105
Without crosstalk	44	92

4.7.7. System Board Minimum Receiver Path Sensitivity Requirements at 2.5 GT/s

The minimum sensitivity values for the system board's Receiver path compliance at 2.5 GT/s are defined in Table 4-19 and Table 4-20. A representative eye diagram is shown in Figure 4-15.

Table 4-19: System Board Minimum Receiver Path Sensitivity Requirements at 2.5 GT/s

Parameter	Min	Max	Unit	Comments
<u>V_{RXS}</u>	445	1200	mV	Notes 1, 2, 5
<u>V_{RXS_d}</u>	312	1200	mV	Notes 1, 2, 5
<u>T_{RXS}</u>	287		ps	Notes 1, 3, 5
<u>J_{RXS-MEDIAN-to-MAX-JITTER}</u>	56.5		ps	Notes 1, 4, 5

Notes:

1. An ideal reference clock without jitter is assumed for this specification. All Links are assumed active while generating this eye diagram.
2. Transition and non-transition bits must be distinguished in order to measure compliance against the de-emphasized voltage level (V_{RXS_d}). V_{RXS} and V_{RXS_d} are differential peak-peak output voltages.
3. T_{RXS} is the eye width. The sample size for this measurement is 10⁶ UI. This value can be reduced to 274 ps for simulation purpose at BER 10⁻¹².

5

10

4. $J_{RXS-MEDIAN-to-MAX-JITTER}$ is the maximum median-to-peak jitter outlier as defined in the *PCI Express Base Specification, Revision ~~4.1~~2.0*. The sample size for this measurement is 10^6 UI. This value can be increased to 63 ps for simulation purpose at BER 10^{-12} .
5. The values in [Table 4-19](#) are referenced to an ideal 100 Ω differential load [at the end of 3-inch 85 \$\Omega\$ differential isolated traces behind a standard connector](#). The resultant values, when provided to the Receiver interconnect path of the system board, allow for a demonstration of compliance of the overall system board Receiver path. The sensitivity requirements are defined and centered with respect to the jitter median. Exact conditions required for verifying compliance while generating this eye diagram are given in the *PHY Electrical Test Considerations for PCI Express Architecture* document.

4.7.8. [System Board Minimum Receiver Path Sensitivity Requirements at 5 GT/s](#)

[Table 4-20: System Board Minimum Receiver Path Sensitivity Requirements at 5 GT/s for a Link that Operates with 3.5 dB De-emphasis](#)

Parameter	Min	Max	Unit	Comments
V_{RXS}	380	1200	mV	Notes 1, 2, 3
V_{RXS_d}	380	1200	mV	Notes 1, 2, 3
1.5 – 100 MHz RMS Jitter	1.4		ps RMS	
< 1.5 MHz RMS Jitter	3.0		ps RMS	
1.5 – 100 MHz DJ	30		ps PP	
> 100 MHz DJ	27		ps PP	

Notes:

1. [All Links are assumed active while generating this eye diagram.](#)
2. [Transition and non-transition bits must be distinguished in order to measure compliance against the de-emphasized voltage level \(V_{RXS_d}\). V_{RXS} and V_{RXS_d} are differential peak-peak output voltages.](#)
3. [The values in Table 4-20 are referenced to an ideal 100 \$\Omega\$ differential load behind 3 inches of isolated 85 \$\Omega\$ trace and a standard PCI Express connector. After reference calibration, the reference fixture is removed and a standard PCI Express edge finger is placed into the PCI Express connector to be tested. The resultant values, when provided to the Receiver interconnect path of the system board, allow for a demonstration of compliance of the overall system board Receiver path. The exact setup and methodology for injecting this signal into the Receiver interconnect path of the system board are not specified. The values in Table 4-20 may need to be adjusted based on the exact test setup and methodology. For example, if the impedance of the test setup does not create the worst case mismatch that could be present with a real add-in card or the test setup does not provide crosstalk \(only a single Lane is tested, etc\), the values in Table 4-13 must be adjusted accordingly.](#)

Table 4-21: System Board Minimum Receiver Path Sensitivity Requirements at 5 GT/s for a Link that Operates with 6.0 dB De-emphasis

<u>Parameter</u>	<u>Min</u>	<u>Max</u>	<u>Unit</u>	<u>Comments</u>
<u>V_{RXS}</u>	<u>306</u>	<u>1200</u>	<u>mV</u>	<u>Notes 1, 2, 3</u>
<u>V_{RXS_d}</u>	<u>260</u>	<u>1200</u>	<u>mV</u>	<u>Notes 1, 2, 3</u>
<u>1.5 – 100 MHz RMS Jitter</u>	<u>1.4</u>		<u>ps RMS</u>	
<u>< 1.5 MHz RMS Jitter</u>	<u>3.0</u>		<u>ps RMS</u>	
<u>1.5 – 100 MHz DJ</u>	<u>30</u>		<u>ps PP</u>	
<u>> 100 MHz DJ</u>	<u>27</u>		<u>ps PP</u>	

Notes:

- All Links are assumed active while generating this eye diagram.
- Transition and non-transition bits must be distinguished in order to measure compliance against the de-emphasized voltage level (V_{RXS_d}). V_{RXS} and V_{RXS_d} are differential peak-peak output voltages.
- The values in Table 4-21 are referenced to an ideal 100 Ω differential load behind 3 inches of isolated 85 Ω trace and a standard PCI Express connector. After reference calibration, the reference fixture is removed and a standard PCI Express edge finger is placed into the PCI Express connector to be tested. The resultant values, when provided to the Receiver interconnect path of the system board, allow for a demonstration of compliance of the overall system board Receiver path. The exact setup and methodology for injecting this signal into the Receiver interconnect path of the system board are not specified. The values in Table 4-21 may need to be adjusted based on the exact test setup and methodology. For example, if the impedance of the test setup does not create the worst case mismatch that could be present with a real add-in card or the test setup does not provide crosstalk (only a single Lane is tested, etc) the values in Table 4-13 must be adjusted accordingly.

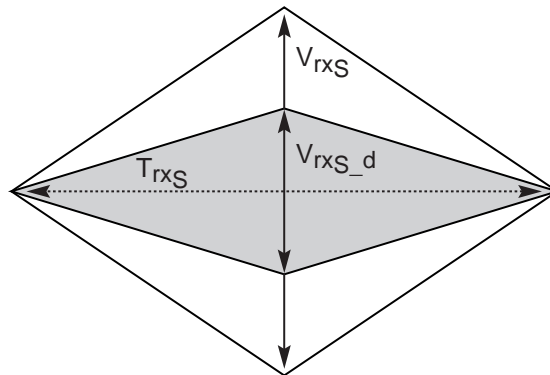

A-0336

Figure 4-15: Representative Composite Eye Diagram for System Board Receiver Path Compliance

5

5. Connector Specification

A family of PCI Express vertical edge card connectors supports x1, x4, x8, and x16 Link widths to suit different bandwidth requirements. These connectors support the PCI Express signal and power requirements, as well as auxiliary signals used to facilitate the interface between system board and add-in card hardware. This chapter defines the connector mating interfaces and footprints, as well as the electrical, mechanical, and environmental requirements.

5.1. Connector Pinout

Table 5-1 shows the pinout definition for the x1, x4, x8, and x16 PCI Express connectors. The auxiliary pins are identified in the shaded areas.

Table 5-1: PCI Express Connectors Pinout

Pin #	Side B		Side A	
	Name	Description	Name	Description
1	+12V	12 V power	PRSENT1#	Hot-Plug presence detect
2	+12V	12 V power	+12V	12 V power
3	+12V	12 V power	+12V	12 V power
4	GND	Ground	GND	Ground
5	SMCLK	SMBus (System Management Bus) clock	JTAG2	TCK (Test Clock), clock input for JTAG interface
6	SMDAT	SMBus (System Management Bus) data	JTAG3	TDI (Test Data Input)
7	GND	Ground	JTAG4	TDO (Test Data Output)
8	+3.3V	3.3 V power	JTAG5	TMS (Test Mode Select)
9	JTAG1	TRST# (Test Reset) resets the JTAG interface	+3.3V	3.3 V power
10	3.3Vaux	3.3 V auxiliary power	+3.3V	3.3 V power
11	WAKE#	Signal for Link reactivation	PERST#	Fundamental reset

Pin #	Side B		Side A	
	Name	Description	Name	Description
Mechanical key				
12	RSVD	Reserved	GND	Ground
13	GND	Ground	REFCLK+	Reference clock (differential pair)
14	PETp0	Transmitter differential pair, Lane 0	REFCLK-	
15	PETn0		GND	Ground
16	GND	Ground	PERp0	Receiver differential pair, Lane 0
17	PRSNT2#	Hot-Plug presence detect	PERn0	
18	GND	Ground	GND	Ground
End of the x1 connector				
19	PETp1	Transmitter differential pair, Lane 1	RSVD	
20	PETn1		GND	Ground
21	GND	Ground	PERp1	Receiver differential pair, Lane 1
22	GND	Ground	PERn1	
23	PETp2	Transmitter differential pair, Lane 2	GND	Ground
24	PETn2		GND	Ground
25	GND	Ground	PERp2	Receiver differential pair, Lane 2
26	GND	Ground	PERn2	
27	PETp3	Transmitter differential pair, Lane 3	GND	Ground
28 28	PETn0 PETn3		GND	Ground
29	GND	Ground	PERp3	Receiver differential pair, Lane 3
30	RSVD	Reserved	PERn3	
31	PRSNT2#	Hot-Plug presence detect	GND	Ground
32	GND	Ground	RSVD	Reserved
End of the x4 connector				
33	PETp4	Transmitter differential pair, Lane 4	RSVD	Reserved
34	PETn4		GND	Ground
35	GND	Ground	PERp4	Receiver differential pair, Lane 4
36	GND	Ground	PERn4	
37	PETp5	Transmitter differential pair, Lane 5	GND	Ground
38	PETn5		GND	Ground

Pin #	Side B		Side A	
	Name	Description	Name	Description
39	GND	Ground	PERp5	Receiver differential pair, Lane 5
40	GND	Ground	PERn5	
41	PETp6	Transmitter differential pair, Lane 6	GND	Ground
42	PETn6		GND	Ground
43	GND	Ground	PERp6	Receiver differential pair, Lane 6
44	GND	Ground	PERn6	
45	PETp7	Transmitter differential pair, Lane 7	GND	Ground
46	PETn7		GND	Ground
47	GND	Ground	PERp7	Receiver differential pair, Lane 7
48	PRSENT2#	Hot-Plug presence detect	PERn7	
49	GND	Ground	GND	Ground
End of the x8 connector				
50	PETp8	Transmitter differential pair, Lane 8	RSVD	Reserved
51	PETn8		GND	Ground
52	GND	Ground	PERp8	Receiver differential pair, Lane 8
53	GND	Ground	PERn8	
54	PETp9	Transmitter differential pair, Lane 9	GND	Ground
55	PETn9		GND	Ground
56	GND	Ground	PERp9	Receiver differential pair, Lane 9
57	GND	Ground	PERn9	
58	PETp10	Transmitter differential pair, Lane 10	GND	Ground
59	PETn10		GND	Ground
60	GND	Ground	PERp10	Receiver differential pair, Lane 10
61	GND	Ground	PERn10	
62	PETp11	Transmitter differential pair, Lane 11	GND	Ground
63	PETn11		GND	Ground
64	GND	Ground	PERp11	Receiver differential pair, Lane 11
65	GND	Ground	PERn11	
66	PETp12	Transmitter differential pair, Lane 12	GND	Ground
67	PETn12		GND	Ground

Pin #	Side B		Side A	
	Name	Description	Name	Description
68	GND	Ground	PERp12	Receiver differential pair, Lane 12
69	GND	Ground	PERn12	
70	PETp13	Transmitter differential pair, Lane 13	GND	Ground
71	PETn13		GND	Ground
72	GND	Ground	PERp13	Receiver differential pair, Lane 13
73	GND	Ground	PERn13	
74	PETp14	Transmitter differential pair, Lane 14	GND	Ground
75	PETn14		GND	Ground
76	GND	Ground	PERp14	Receiver differential pair, Lane 14
77	GND	Ground	PERn14	
78	PETp15	Transmitter differential pair, Lane 15	GND	Ground
79	PETn15		GND	Ground
80	GND	Ground	PERp15	Receiver differential pair, Lane 15
81	PRCNT2#	Hot-Plug presence detect	PERn15	
82	RSVD	Reserved	GND	Ground

End of the x16 connector

The following points should be noted:

- ❑ The pins are numbered as shown in Figure 5-2 in ascending order from the left to the right, with side A on the top of the centerline and side B on the bottom of the centerline.
- ❑ The PCI Express interface pins PETpx, PETnx, PERpx, and PERnx are named with the following convention: “PE” stands for PCI Express *high speed*, “T” for *Transmitter*, “R” for *Receiver*, “p” for *positive (+)*, and “n” for *negative (-)*.
- ❑ By default, PETpx and PETnx pins (the Transmitter differential pair of the connector) shall be connected to the PCI Express Transmitter differential pair on the system board, and to the PCI Express Receiver differential pair on the add-in card.
- ❑ By default, PERpx and PERnx pins (the Receiver differential pair of the connector) shall be connected to the PCI Express Receiver differential pair on the system board, and to the PCI Express Transmitter differential pair on the add-in card.
- ❑ However, the “p” and “n” connections may be reversed to simplify PCB trace routing and minimize vias if needed. All PCI-Express Receivers incorporate automatic Lane Polarity Inversion as part of the Link Initialization and Training and will correct the polarity independently on each Lane. Refer to Section 4.2.4. of the *PCI Express Base Specification, Revision ~~4.1~~2.0*.

- ❑ If the component on the system board or add-in card does not support the optional PCI Express Lane Reversal functions, they must connect each Transmitter and Receiver Lane to the add-in card connector lanes as shown in Table 5-1. For example, a x4 component must connect Lane 0 to 0, Lane 1 to 1, Lane 2 to 2, and Lane 3 to 3.
- 5 ❑ If the component on the system board or add-in card supports the optional PCI Express Lane Reversal function, it may connect each Transmitter and Receiver Lane to the add-in card connector lanes as shown in Table 5-1 or it may connect the Transmitter and Receiver lanes using a reversed Lane ordering. Either Lane ordering may be used to simplify PCB trace routing and minimize vias. However, the transmitting and receiving lanes must be connected with the
10 same Lane ordering. For example, a x4 component may connect Lane 0 to 0, Lane 1 to 1, Lane 2 to 2, and Lane 3 to 3 or it may connect Lane 0 to 3, Lane 1 to 2, Lane 2 to 1, and Lane 3 to 0.
- ❑ The connectors and the add-in cards are keyed such that smaller add-in cards can be put in larger connectors. For example, a x1 card can be inserted into the x4, x8, and x16 connectors.
15 This is referred to as up-plugging.
- ❑ Adjacent differential pairs are separated by two ground pins to manage the connector crosstalk.
- ❑ See Chapter 2 for auxiliary signals description and implementation, except the +3.3Vaux and PRSNT1# and PRSNT2# pins. The requirements for +3.3Vaux are discussed in Chapter 4 and presence detect is discussed in Chapter 3.
- 20 ❑ PRSNT1# and PRSNT2# pins are for card presence detect. One present detect pin at each end of a connector guarantees that at least one of the present detect pins is last-mate/first-break. More than two PRSNT2# pins in the x4, x8, and x16 PCI Express connectors are for the purpose of supporting up-plugging. See Chapter 3 for detailed discussions on presence detect.
- ❑ The sequential mating for Hot-Plug is accomplished by staggering the edge fingers on the add-in
25 card, as shown in Section 5.2. Detailed requirements on Hot-Plug are covered in Chapter 3.
- ❑ Power pins (+3.3V, +3.3Vaux, and +12V) are defined based on the PCI Express power delivery requirements specified in Chapter 4, with the connector contact carrying capability being 1.1 A per pin. The power that goes through the connector shall not exceed the maximum power specified for a given add-in card size, as defined in Table 4-2.

5.2. Connector Interface Definitions

- 30 The PCI Express connector outline, footprint, and the corresponding add-in card edge-finger dimensions are shown in Figure 5-1, Figure 5-2, and Figure 5-3.

PCI EXPRESS CARD ELECTROMECHANICAL SPECIFICATION, REV. 4.2.0

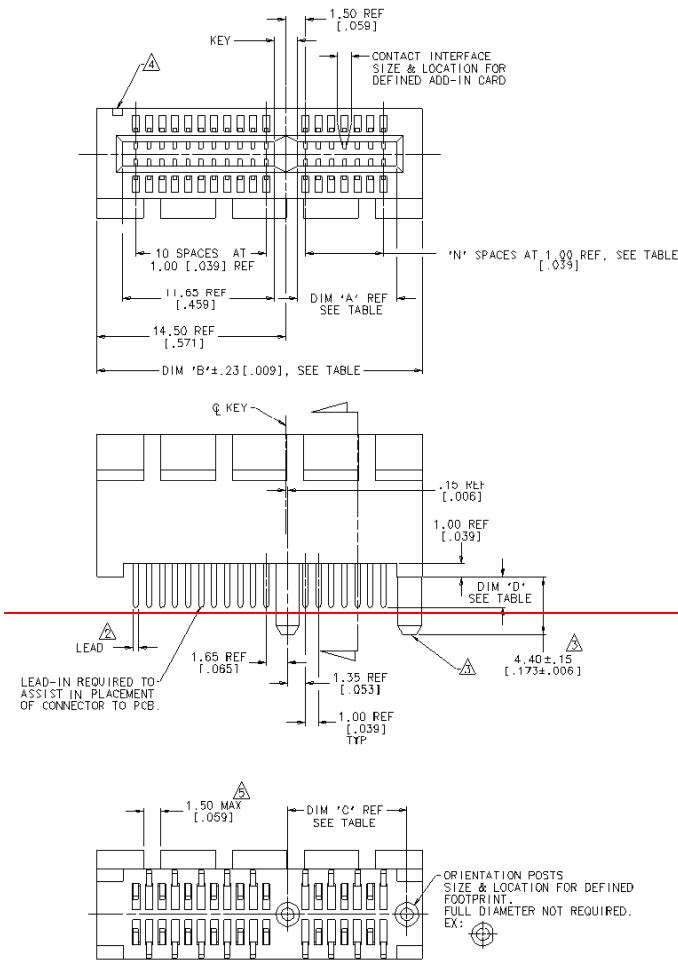

- △ BY DESIGN.
- △ SIZE & LOCATION FOR DEFINED FOOTPRINT AND MEET THE FOLLOWING REQUIREMENT:
 - △ THE DIFFERENCE BETWEEN THE NOMINAL HOLE DIAMETER, .70 [.028] AND THE NOMINAL DIAGONAL DIMENSION 'A' OF THE SOLDER TAIL CROSS-SECTION, .70-A ≥ .25.
- △ POST CHAMFER SHOULD BE SIZED SO THAT THE MAJOR DIAMETER OF THE POST IS ENGAGED WITH THE PCB HOLE PRIOR TO THE LEADS ENTERING THE PLATED THRU HOLES.
- △ PIN #A1 IDENTIFIER.
- △ FREQUENCY & LOCATION AT SUPPLIER DISCRETION. RIDGE MAY BE CONTINUOUS WITH NO BREAKS.

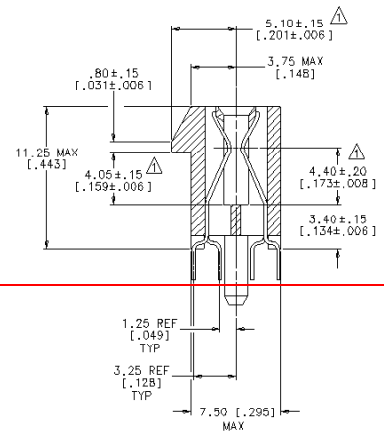

CONNECTOR LINK WIDTH	# POS REF	N	DIM 'A'	DIM 'B'	DIM 'C'	PCB THK (REF)	DIM 'D'
X1	36	6	7.65 [.301]	25.00 [.984]	9.15 [.360]	1.58 [.062]	2.30 +.25/- .13 [.091 +.010/- .065]
X4	64	20	21.65 [.852]	39.00 [1.535]	23.15 [.911]	2.36 [.093]	3.10 +.25/- .13 [.122 +.010/- .065]
X8	96	37	38.65 [1.522]	56.00 [2.205]	40.15 [1.581]		
X16	164	70	71.65 [2.821]	89.00 [3.504]	73.15 [2.880]		

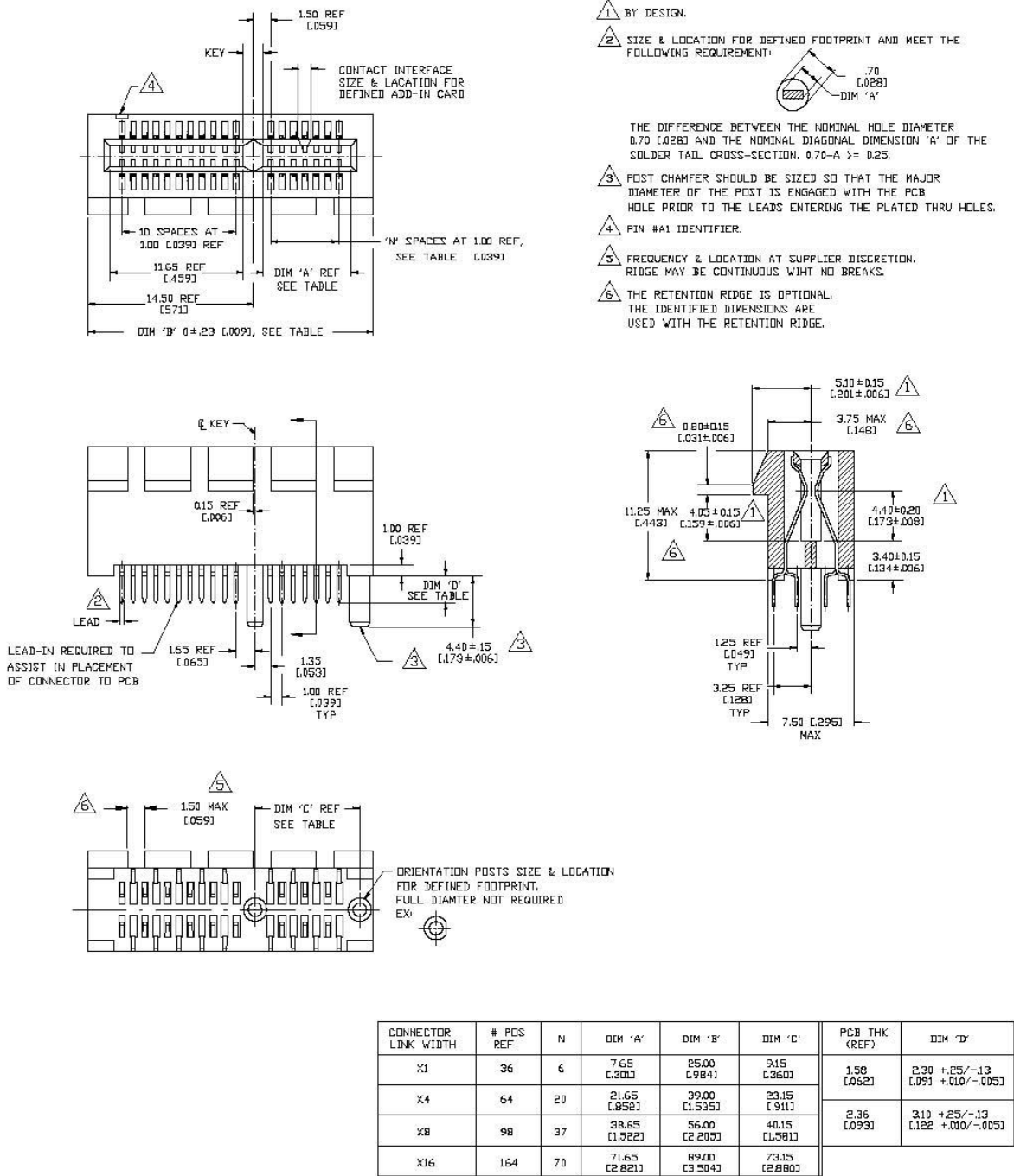
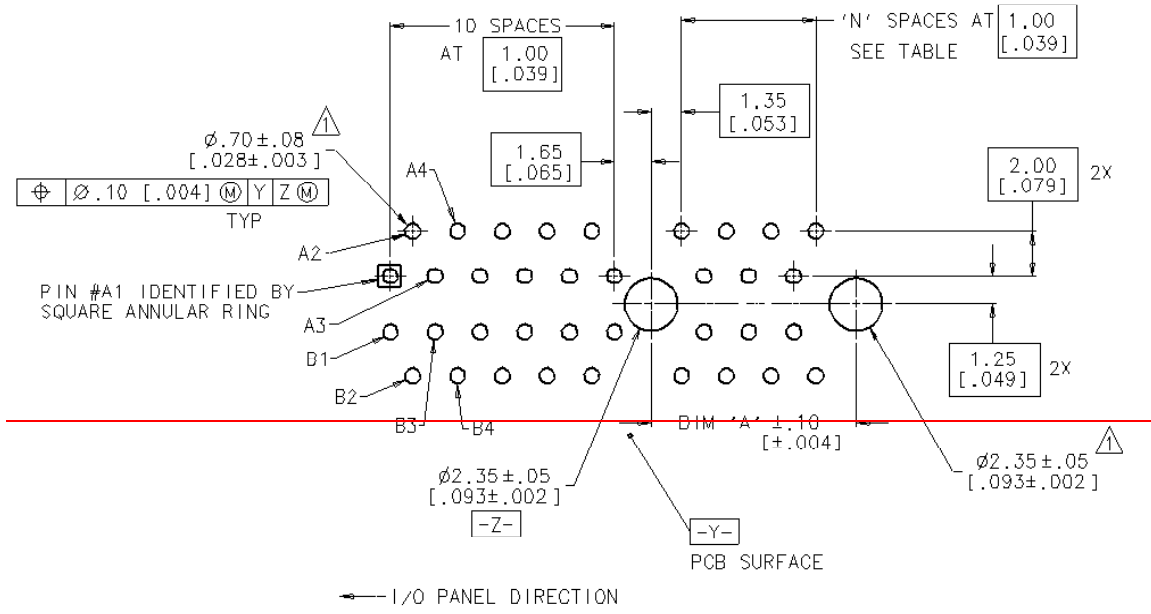
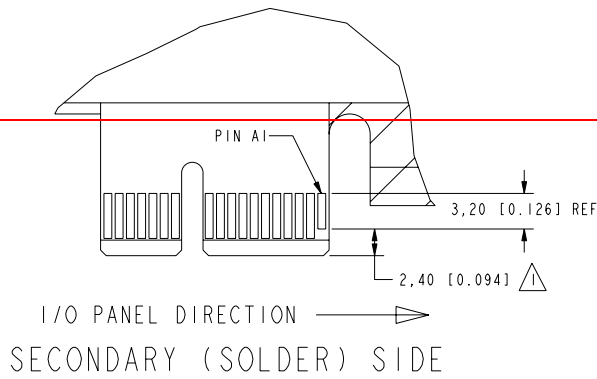
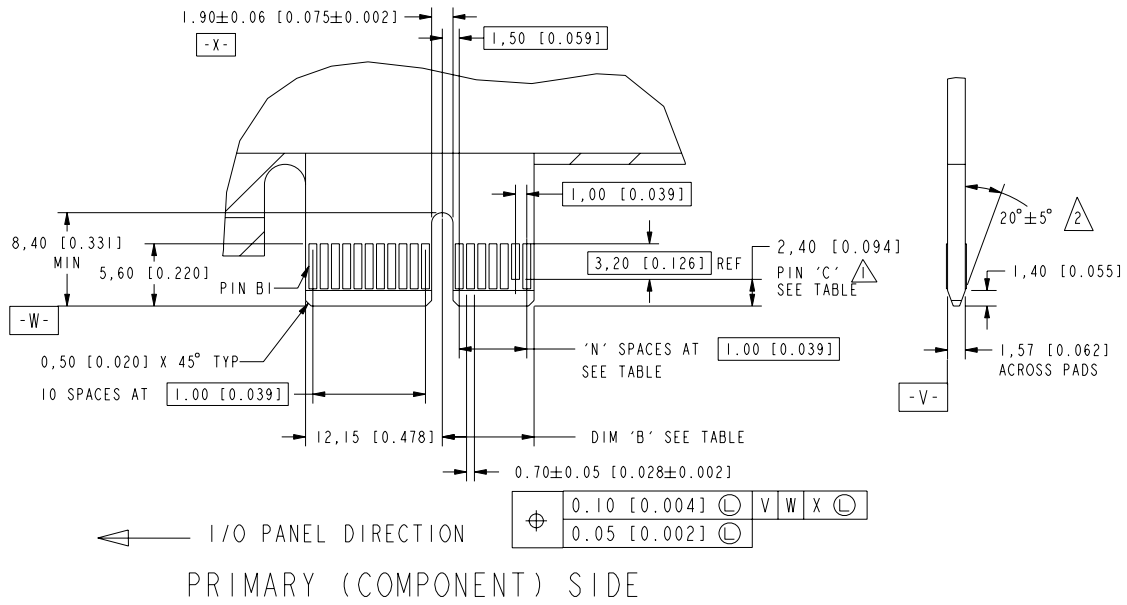

Figure 5-1: Connector Form Factor

△ THE HORIZONTAL AXIS FOR THE HOLE PATTERN IS ESTABLISHED BY A LINE THROUGH THE CENTER OF THE TWO $\phi 2.35$ HOLES. THE VERTICAL AXIS IS 90° TO THE HORIZONTAL AXIS, THROUGH THE CENTER OF DATUM [-Z-].



CONNECTOR LINK WIDTH	# POS REF	N	DIM 'A'
X 1	36	6	9.15 [.360]
X 4	64	20	23.15 [.911]
X 8	98	37	40.15 [1.581]
X 16	164	70	73.15 [2.880]



- 1 NO TIE BAR PERMITTED FROM CARD EDGE TO LEADING EDGE OF PAD FOR PINS A1 AND 'C'.
- 2 CHAMFER EDGES MUST BE FREE OF CUTTING BURRS.
3. TOLERANCE: .XX ±0,13 [0.005]

CONNECTOR LINK WIDTH	# POS REF	N	DIM 'B'	'C' 1
X1	36	6	8.15 [0.321]	B17
X4	64	20	22.15 [0.872]	B31
X8	98	37	39.15 [1.541]	B48
X16	164	70	72.15 [2.841]	B81

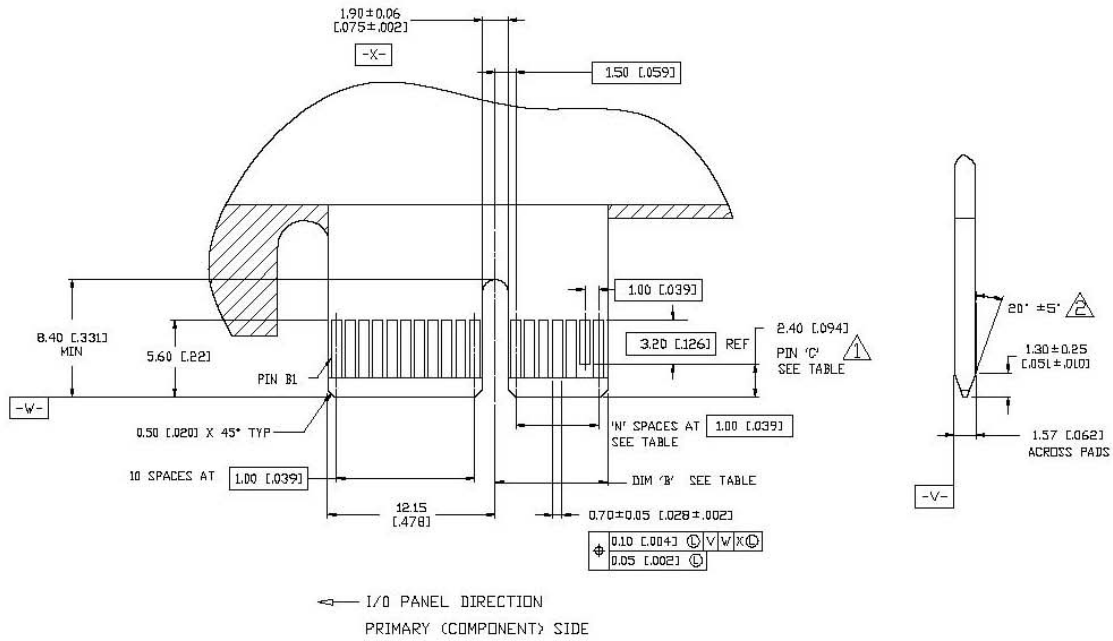

- 1 NO TIE BAR PERMITTED FROM CARD EDGE TO LEADING EDGE OF PAD FOR PINS A1 AND 'C'.
- 2 CHAMFER EDGES MUST BE FREE OF CUTTING BURRS.
- 3 TOLERANCE: .XX ± 0.13 [0.05]

CONNECTOR LINK WIDTH	# PDS REF	N	DIM 'B'	'C' ¹
X1	36	6	8.15 [0.321]	B17
X4	64	20	22.15 [0.872]	B31
X8	98	37	39.15 [1.541]	B48
X16	164	70	72.15 [2.841]	B81

Figure 5-3: Add-in Card Edge-Finger Dimensions

The following points should be noted:

- ❑ The connector has a 1.00 mm contact pitch.
 - ❑ The contact shall be pre-loaded, similar to the PCI connector.
 - ❑ The connector footprint (Figure 5-2) requires two 2.35 mm diameter location holes, working with either plastic pegs/posts or metal board locks. Metal board locks are allowed, although Figure 5-1 shows only the plastic pegs on the connector housing.
 - ❑ Figure 5-3 defines only the mating interface related dimensions. Other add-in card dimensions are defined in Chapter 6.
 - ❑ The PRSNT1# and PRSNT2# pins shown in Figure 5-3 are 1 mm shorter than the other fingers. Those pins are designated as A1, B17, B31, B48, and B81, where applicable. No plating tie bar is allowed underneath the PRSNT1# and PRSNT2# pins because those pins are meant to be last-mate and first-break.
 - ❑ As shown in Figure 5-1, [an optional](#) ridge feature is defined on the top of the connector housing on one side. This feature can be used to facilitate card retention. A retention clip may be mounted on an add-in card and latched on the ridge.
 - ❑ Two types of add-in cards must be “retention ready”:
 - Graphics cards
 - x1, x4, x8, or x16 I/O cards that in the judgment of the OEM or card manufacturers have sufficient weight or length that the card may need an additional retention point for stability
- Retention ready* means that the add-in card manufacturer must have selected (or created) a retention mechanism and made provisions on the card to facilitate the retention mechanism. The reference retention mechanism designs and related component keep-out or height restriction areas are defined in the *PCI Express Graphics Card Thermal Mechanical Design Guidelines*.
- The full-length card 321.00 mm (12.283 inches) long is considered retention ready. The mounting holes on one end of the full-length card allow the optional PCI card retainer to be installed to secure the card. See Section 6.1.
- ❑ Detailed connector contact and housing designs are up to each connector vendor, as long as the requirements of form, fit, and function are met.

5.3. Signal Integrity Requirements and Test Procedures

5.3.1. Signal Integrity Requirements

The procedures outlined in the following ANSI Electronics Industry Alliance (EIA) standards documents shall be followed:

- ❑ [EIA 364-101 – Attenuation Test Procedure for Electrical Connectors, Sockets, Cable Assemblies or Interconnection Systems](#)
- 5 ❑ [EIA 364-90 – Crosstalk Ratio Test Procedure for Electrical Connectors, Sockets, Cable Assemblies or Interconnection Systems](#)
- ❑ [EIA 364-108 – Impedance, Reflection Coefficient, Return Loss, and VSWR Measured in the Time and Frequency Domain Test Procedure for Electrical Connectors, Sockets, Cable Assemblies or Interconnection Systems](#)

5.3.2. Signal Integrity Requirements and Test Procedures for 2.5 GT/s Support

10 A common electrical test fixture is specified and used for evaluating connector signal integrity. The test fixture will have .1524-mm (6-mil) wide 50- Ω single ended traces that must be uncoupled. The impedance variation of those traces shall be controlled within $\pm 5\%$. Refer to the *PCI Express Connector High Speed Electrical Test Procedure* for detailed discussions on the test fixture.

15 Detailed testing procedures, ~~such as the vector network analyzer settings, operation, and calibration~~ are specified in the *PCI Express Connector High Speed Electrical Test Procedure*. This document should be used in conjunction with the standard test fixture.

For the insertion loss and return loss tests, the measurement shall include 1.2-inch long PCB traces (0.6 inches on the system board and 0.6 inches on the add-in card). Note that the edge finger pad is not counted as the add-in card PCB trace. It is considered to be part of the connector interface.

20 The 1.2-inch PCB trace included in the connector measurement is a part of the trace length allowed on the system board. See Section 4.6 for a discussion of the electrical budget.

25 Either single ended measurements that are processed to extract the differential characteristics or true differential measurements are allowed. The detailed definition and description of the test fixture and the measurement procedures are provided separately in a document entitled *PCI Express Connector High Speed Electrical Test Procedure*.

30 An additional consideration for the connector electrical performance is the connector-to-system board and the connector-to-add-in-card launches. The connector through hole pad and anti-pad sizes shall follow good electrical design practices to minimize impedance discontinuity. On the add-in card, the ground and power planes underneath the PCI Express high-speed signals (edge fingers) shall be removed. Otherwise the edge fingers will have too much capacitance and greatly degrade connector performance. A more detailed discussion on the add-in card electrical design can be found in the *PCI Express Connector High Speed Electrical Test Procedure*.

Table 5-2 lists the electrical signal integrity parameters, requirements, and test procedures.

Table 5-2: Signal Integrity Requirements and Test Procedures [For 2.5 GT/s Support](#)

Parameter	Procedure	Requirements
Differential Insertion Loss (DDIL)	<p>EIA 364-101</p> <p>The EIA standard must be used with the following considerations:</p> <ol style="list-style-type: none"> 1. The step-by-step measurement procedure is outlined in the <i>PCI Express Connector High Speed Electrical Test Procedure</i> document (see Note 1 below). 2. A common test fixture for connector characterization shall be used. 3. This is a differential insertion loss requirement. Either true differential measurements must be made or post processing of the single ended measurements must be done to extract the differential characteristics of the connector. The methodology of doing so is covered in the <i>PCI Express Connector High Speed Electrical Test Procedure</i> document (Note 1). 	<p>≤ 1 dB max up to 1.25 GHz;</p> <p>$\leq [1.6*(F-1.25)+1]$ dB for 1.25 GHz < F f ≤ 3.75 GHz (for example, ≤ 5 dB at F $f = 3.75$ GHz)</p>
Differential Return Loss (DDRL)	<p>EIA 364-108</p> <p>The EIA standard must be used with the following considerations:</p> <ol style="list-style-type: none"> 1. The step-by-step measurement procedure is outlined in the <i>PCI Express Connector High Speed Electrical Test Procedure</i> document (Note 1). 2. A common test fixture for connector characterization shall be used. 3. This is a differential return loss requirement. Either true differential measurements must be made or post processing of the single ended measurements must be done to extract the differential characteristics of the connector. The methodology of doing so is covered in the <i>PCI Express Connector High Speed Electrical Test Procedure</i> document (Note 1). 	<p>≤ -12 dB up to 1.3 GHz; ≤ -7 dB up to 2 GHz; ≤ -4 dB up to 3.75 GHz</p> <p>≤ -7 dB for 1.3 GHz < $f \leq 2$ GHz;</p> <p>≤ -4 dB for 2 GHz < $f \leq 3.75$ GHz</p>
Intra-pair Skew	Intra-pair skew must be achieved by design; measurement not required.	5 ps max

Parameter	Procedure	Requirements
Differential Near End Crosstalk: DDNEXT	<p>EIA 364-90</p> <p>The EIA standard must be used with the following considerations:</p> <ol style="list-style-type: none"> 1. The crosstalk requirement is with respect to all the adjacent differential pairs including the crosstalk from opposite sides of the connector, as illustrated in Figure 5-4. This is reflected in the measurement procedure. 2. The step-by-step measurement procedure is outlined in the <i>PCI Express Connector High Speed Electrical Test Procedure</i> document. 3. A common test fixture for connector characterization shall be used. 4. This is a differential crosstalk requirement between a victim differential signal pair and all of its adjacent differential signal pairs. Either true differential measurements must be made or post processing of the single ended measurements must be done to extract the differential crosstalk of the connector. The methodology of doing so is covered in the <i>PCI Express Connector High Speed Electrical Test Procedure</i> document (see Note 1 below). 	<p>≤ -32 dB max up to 1.25 GHz;</p> <p>$\leq -[32-2.4*(F-1.25)]$ dB for $1.25 \text{ GHz} < F \leq 3.75 \text{ GHz}$ (for example, ≤ -26 dB at $F = 3.75 \text{ GHz}$)</p>
Jitter	By design; measurement not required.	10 ps max

Notes:

1. The *PCI Express Connector High Speed Electrical Test Procedure* is available separately.
2. A [typical approach to making these measurements is with a network analyzer](#) ~~is required~~ [or a TDR oscilloscope](#). Differential measurements require the use of a two port (or a four port) ~~network analyzer~~ [instrument](#) to measure the connector. The differential parameters may be measured directly if the equipment supports “True” differential excitation (“True” differential excitation is the simultaneous application of a signal to one line of the pair and a 180 degree phase shifted version of the signal to the second line of the pair). If single ended measurements are made, the differential connector parameters must be derived from the single ended measurements as defined in the *PCI Express Connector High Speed Electrical Test Procedure*.
3. The connector shall be targeted for a 100 Ω differential impedance.

In [Figure 5-4](#), pairs marked as 11-9, 5-7, 15-13, and 17-19 are the adjacent pairs with respect to the victim pair 1-3.

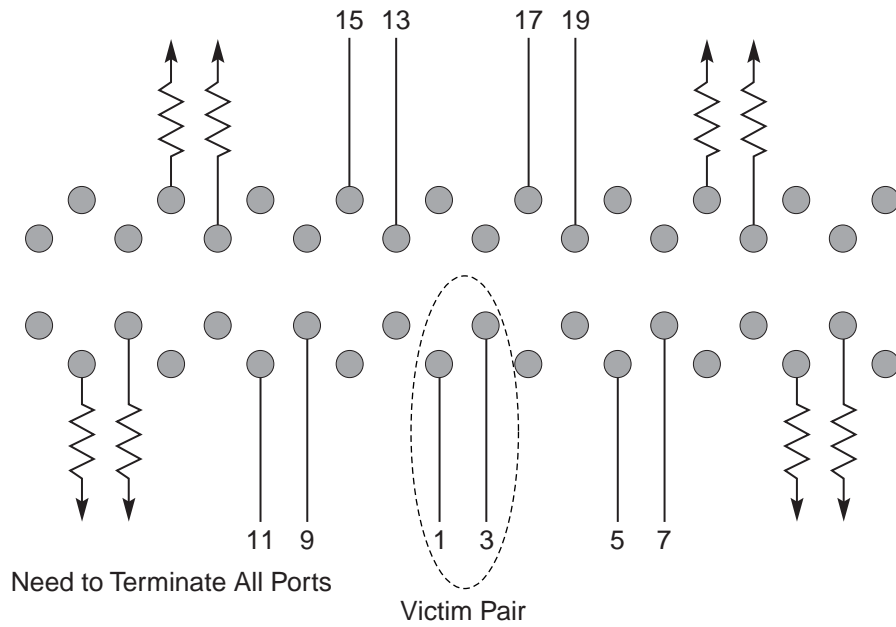

OM14761

Figure 5-4: Illustration of Adjacent Pairs

5.3.3. [Signal Integrity Requirements and Test Procedures for 5 GT/s Support](#)

[An electrical test fixture must be used for evaluating connector signal integrity. The test fixture effects, not including the connector via, are deembedded from measurements. A section is provided with test fixture requirements and recommendations.](#)

[Table 5-3 lists the electrical signal integrity parameters, requirements, and test procedures.](#)

Table 5-3: Signal Integrity Requirements and Test Procedures for 5 GT/s Support

<u>Parameter</u>	<u>Procedure</u>	<u>Requirements</u>
<u>Differential Insertion Loss (DDIL)</u>	<p><u>EIA 364-101</u></p> <p>The EIA standard shall be used with the following considerations:</p> <ol style="list-style-type: none"> <u>The measured differential S parameter shall be referenced to an 85 Ω differential impedance.</u> <u>The test fixture shall meet the test fixture requirement defined in Section 5.4.2.</u> <u>The test fixture effect shall be removed from the measured S parameters. Refer to Note 1.</u> 	<p><u>≥-0.5 dB up to 2.5 GHz;</u></p> <p><u>≥-[0.8*(f-2.5)+0.5] dB for 2.5 GHz < f ≤ 5 GHz (for example, ≥-2.5 dB at f = 5 GHz);</u></p> <p><u>≥-[3.0*(f-5)+2.5] dB for 5 GHz < f ≤ 7.5 GHz (for example, ≥-10 dB at f = 7.5 GHz)</u></p>
<u>Differential Return Loss (DDRL)</u>	<p><u>EIA 364-108</u></p> <p>The EIA standard shall be used with the following considerations:</p> <ol style="list-style-type: none"> <u>The measured differential S parameter shall be referenced to an 85 Ω differential impedance.</u> <u>The test fixture shall meet the test fixture requirement in Section 5.4.2.</u> <u>The test fixture effect shall be removed. Refer to Note 1.</u> 	<p><u>≤ -15 dB up to 3.0 GHz;</u></p> <p><u>≤ -5 dB for 3.0 GHz < f ≤ 5 GHz;</u></p> <p><u>≤ -1 dB for 5.0 GHz < f ≤ 7.5 GHz</u></p>
<u>Intra-pair Skew</u>	<u>Intra-pair skew must be achieved by design; measurement not required.</u>	<u>5 ps max</u>
<u>Differential Near End Crosstalk (DDNEXT)</u>	<p><u>EIA 364-90</u></p> <p>The EIA standard must be used with the following considerations:</p> <ol style="list-style-type: none"> <u>The crosstalk requirement is with respect to all the adjacent differential pairs including the crosstalk from opposite sides of the connector, as illustrated in Figure 5-4.</u> <u>This is a differential crosstalk requirement between a victim differential signal pair and all of its adjacent differential signal pairs. The measured differential S parameter shall be referenced to an 85 Ω differential impedance.</u> 	<p><u>≤ -32 dB up to 2.5 GHz;</u></p> <p><u>≤ -26 dB for 2.5 GHz < f ≤ 5.0 GHz;</u></p> <p><u>≤ -20 dB for 5.0 GHz < f ≤ 7.5 GHz</u></p>

Notes:

- The specified S parameters requirements are for connector only, not including the test fixture effect. While the TRL calibration method is recommended, other calibration methods are allowed.

5.3.3.1 *Test Fixture Requirements*

The test fixture for connector S-parameter measurement should be designed and built to the following requirements:

The test fixture shall be an FR4-based PCB of the microstrip structure; the dielectric thickness or stackup shall be approximately .102 mm (4 mils).

The total thickness of the test fixture PCB shall be 1.57 mm (0.62") and the test add-in card should be a break-out card fabricated in the same PCB panel for the fixture.

The measurement signals shall be launched into the connector from the top of the test fixture, capturing the through-hole stub effect.

Traces between the connector and measurement ports (SMA or microprobe) should be uncoupled.

The trace lengths between the connector and measurement port shall be minimized. The maximum trace length shall not exceed 45.72 mm (1800 mils). The trace lengths between the connector and measurement port on the test baseboard and add-in card shall be equal. Note that the edge finger pad is not counted as the add-in card PCB trace; it is considered as a part of the connector interface.

All of the traces on the test board and add-in card must be held to a characteristic impedance of 50 Ω with a tolerance of $\pm 7\%$.

The test add-in card edge finger pads shall be fabricated per mechanical specification defined in Figure 5-3. The ground plane immediately underneath the edge finger pads must be removed.

The through-hole on the test board shall have the following stackup: .711-mm (28-mil) finished hole, 1.067-mm (42-mil) pad, and 1.473-mm (58-mil) anti-pad.

Use of SMA connectors is recommended. The SMA launch structure shall be designed to minimize the connection discontinuity from SMA to the trace. The impedance range of the SMA seen from a TDR with a 60 ps rise time is recommended to be within 50 $\pm 7 \Omega$.

If a fixture with other characteristics is used, the fixture effects must be reliably removed and must not impact measurement accuracy.

5.4. Connector Environmental and Other Requirements

5.4.1. Environmental Requirements

Connector environmental tests shall follow EIA-364-1000.01, Environmental Test Methodology for Assessing the Performance of Electrical Connectors and Sockets Used in Business Office Applications. The test groups/sequences and durations shall be derived from the following requirements:

- Durability (mating/unmating) rating of 50 cycles
- Field temperature: 65 °C
- Field life: seven years

Since the connector defined in Section 5.2 has far more than 0.127 mm wipe length, Test Group 6 in EIA-364-1000.01 is not required. Test Group 7 in EIA-364-1000.01 is optional since the durability cycles is ≤ 50 . The temperature life test duration and the mixed flowing gas test duration values are derived from EIA 364-1000.01 based on the field temperature, using simple linear interpolation. Table 5-4 lists these values.

Table 5-4: Test Durations

Test	Duration/Temperature
Temperature Life	168 hours at 105 °C
Temperature Life (preconditioning)	92 hours at 105 °C
Mixed Flowing Gas	10 days

The low level contact resistance (LLCR) is required to be 30 mΩ or less, initially. Note that the contact resistance measurement points shall include the solder tail and the contact-mating interface, as illustrated in Figure 5-5. The resistance change, which is defined as the change in LLCR between the reading after stress and the initial reading, shall not exceed the value that is to be specified by each OEM to best suit their needs.

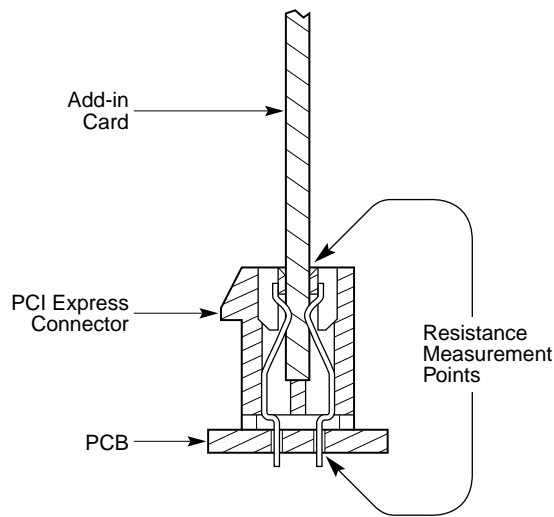

OM14762

Figure 5-5: Contact Resistance Measurement Points

To be sure that the environmental tests measure the stability of the connector, the add-in cards used shall have edge finger tabs with a minimum plating thickness of 30 microinches of gold over 50 microinches of nickel *for the environmental test purpose only*. Furthermore, it is highly desirable that testing gives an indication of the stability of the connector when add-in cards at the lower and upper limit of the card thickness requirement are used. In any case, both the edge tab plating thickness and the card thickness shall be recorded in the environmental test report.

5.4.2. Mechanical Requirements

Table 5-5 lists the mechanical parameters and requirements. Note that the sample size shall follow Section 2.2.1 of EIA-364-1000.01.

Table 5-5: Mechanical Test Procedures and Requirements

Test Description	Procedure	Requirement
Visual and dimensional inspections	EIA 364-18 Visual, dimensional, and functional per applicable quality inspection plan	Meets product drawing requirements
Insertion force	EIA 364-13 Measure the force necessary to mate the connector assemblies at a maximum rate of 12.5 mm (0.492 inches) per minute, using a steel gauge 1.70 mm thick with a tolerance + 0.00, - .01 mm.	1.15 N maximum per contact pair
Removal force	EIA 364-13 Measure the force necessary to unmate the connector assemblies at maximum rate of 12.5 mm (0.492 inches) per minute, using a steel gauge 1.44 mm thick with a tolerance + .01, - 0.00 mm.	0.15 N minimum per contact pair

5.4.3. Current Rating Requirement

Table 5-6 lists the contact current rating requirement and test procedure.

Table 5-6: End of Life Current Rating Test Sequence

Test Order	Test	Procedure	Condition	Requirement
1	Contact current rating	<p>EIA 364-70 method 2</p> <p>The sample size is a minimum of three mated connectors.</p> <p>The sample shall be soldered on a PC board with the appropriate footprint.</p> <p>Wire the eight power pins (B1, B2, B3, A2, A3, B8, A9, and A10) and the eight nearest ground pins (A4, B4, B7, A12, B13, A15, B16, and B18) in a series circuit. The mated add-in card is included in this circuit. The add-in card shall have 1 oz. copper traces and its mating geometry shall conform to the applicable PCI Express drawings.</p> <p>A thermocouple of 30 AWG or less shall be placed on the card edge finger pad (pins B2 and A9) as close to the mating contact as possible.</p> <p>Conduct a temperature rise vs. current test.</p>	Mated	<p>1.1 A per pin minimum</p> <p>The temperature rise above ambient shall not exceed 30 °C. The ambient condition is still air at 25 °C.</p>

5.4.4. Additional Considerations

Table 5-7 lists the additional requirements.

Table 5-7: Additional Requirements

Parameter	Procedure	Requirement
Flammability	UL94V-1 minimum	Material certification or certificate of compliance required with each lot to satisfy the Underwriters Laboratories follow-up service requirements.
Lead-free soldering		Connector must be compatible with lead free soldering process.
Connector Color		Color of the connector should be black. Exceptions will be made for color coding schemes that call for a different color of this connector.

5 This specification does not attempt to define the connector requirements that are considered application-specific. It is up to the users and their connector suppliers to determine if additional requirements shall be added to satisfy the application needs. The system level shock and vibration tests are considered application-specific because results will depend on card weight and size, chassis stiffness, and retention mechanisms, as well as the connector. Therefore those tests are not specified in the connector specification. It will be up to each system OEM to decide how the shock and vibration tests shall be done.



6. Add-in Card Form Factors and Implementation

6.1. Add-in Card Form Factors

To enable the reuse of existing chassis slots, the PCI Express add-in cards are similar to the PCI add-in card form factor. Two PCI Express add-in card heights are defined: the standard height of 111.15 mm (4.376 inches) maximum and the low profile of 68.90 mm (2.731 inches) maximum. Note that card height is measured from the bottom of the edge finger to the top of the card (see Figure 6-1 and Figure 6-3). Table 6-1 lists the add-in card sizes corresponding to different PCI Express Link widths.

Table 6-1: Add-in Card Sizes

Link Width		Height	Length
x1, <u>x4, x8</u> ⁴	Standard height, half length card	111.15 mm (4.376 inches) maximum	167.65 mm (6.600 inches) maximum
x1, x4, x8, x16	Standard height, full length cards	111.15 mm (4.376 inches) maximum	312.00 mm (12.283 inches) maximum ⁵
	Low profile cards	68.90 mm (2.731 inches) maximum	167.65 mm (6.600 inches) maximum

~~*Not all system designs will support this length of add-in card. It is strongly recommended that standard height add-in cards be designed with a 241.30 mm (9.5 inches) maximum length.~~

The x1 cards allow two different maximum lengths. The x1 standard height, half length card has a maximum length of 167.65 mm (6.600 inches), with applications in the mainstream desktop and other platforms. The x1 standard height, full-length card allows a maximum length of 312.00 mm (12.283 inches). It is defined for applications that require more real estate than the half length card provides.

It should be noted that the maximum length specifies what the system design must accommodate. An add-in card can be any length up to the maximum for a particular Link width. For example, a x4

⁴ [As described in Table 4-2 a x1 add-in card that consumes more than 10 W must have a length greater than the half length card maximum.](#)

⁵ [Not all system designs will support this length of add-in card. It is strongly recommended that standard height add-in cards be designed with a 241.30 mm \(9.5 inches\) maximum length.](#)

standard height card with a 177.80-mm (7.00-inches) length can be installed in a system that accommodates 241.30 mm (9.5 inches) maximum length cards, but a system that only accommodates 167.65 mm (6.6 inches) maximum length cards will not support this card.

Figure 6-1 and Figure 6-2 show the standard PCI Express card form factor without and with the I/O bracket, respectively.

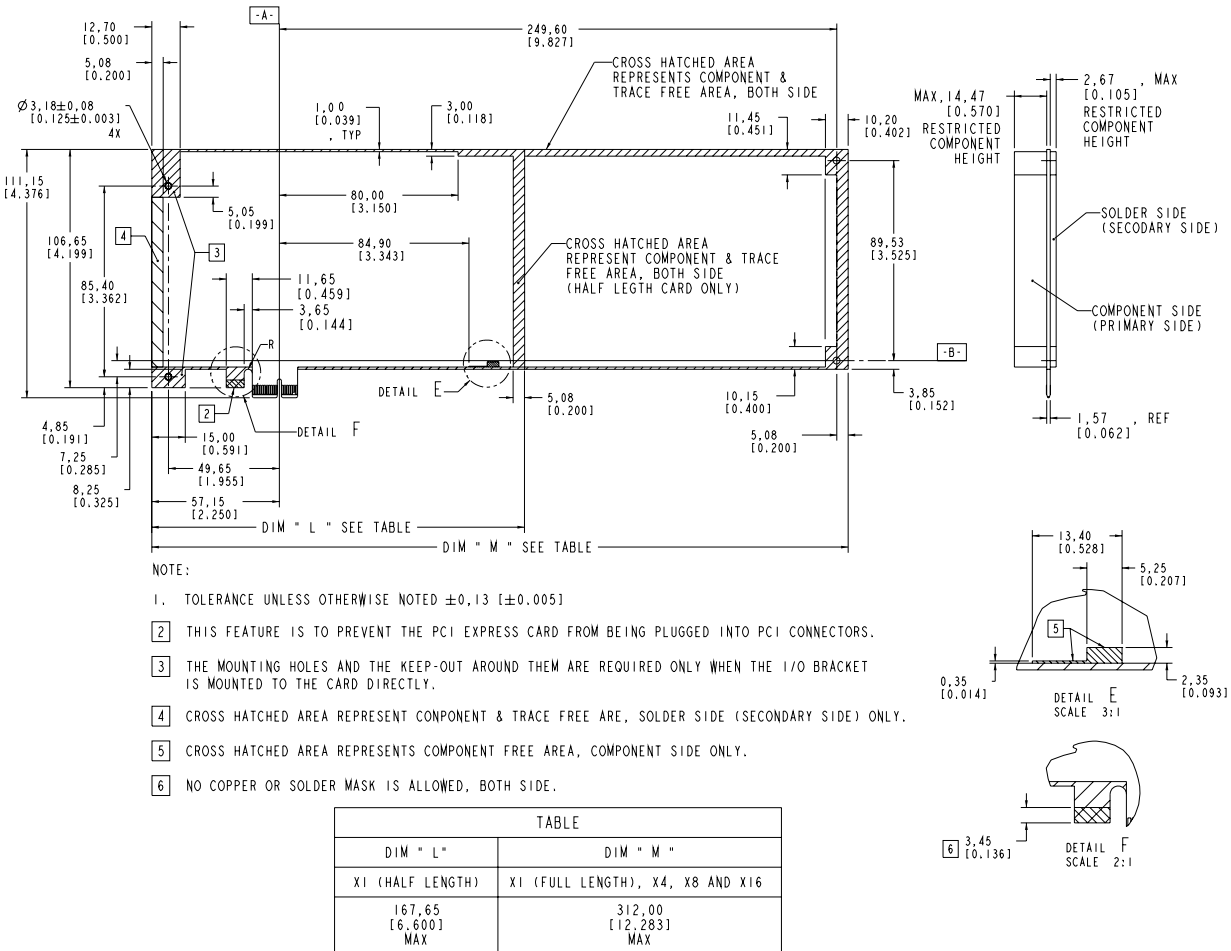

Figure 6-1: Standard Height PCI Express Add-in Card without the I/O Bracket

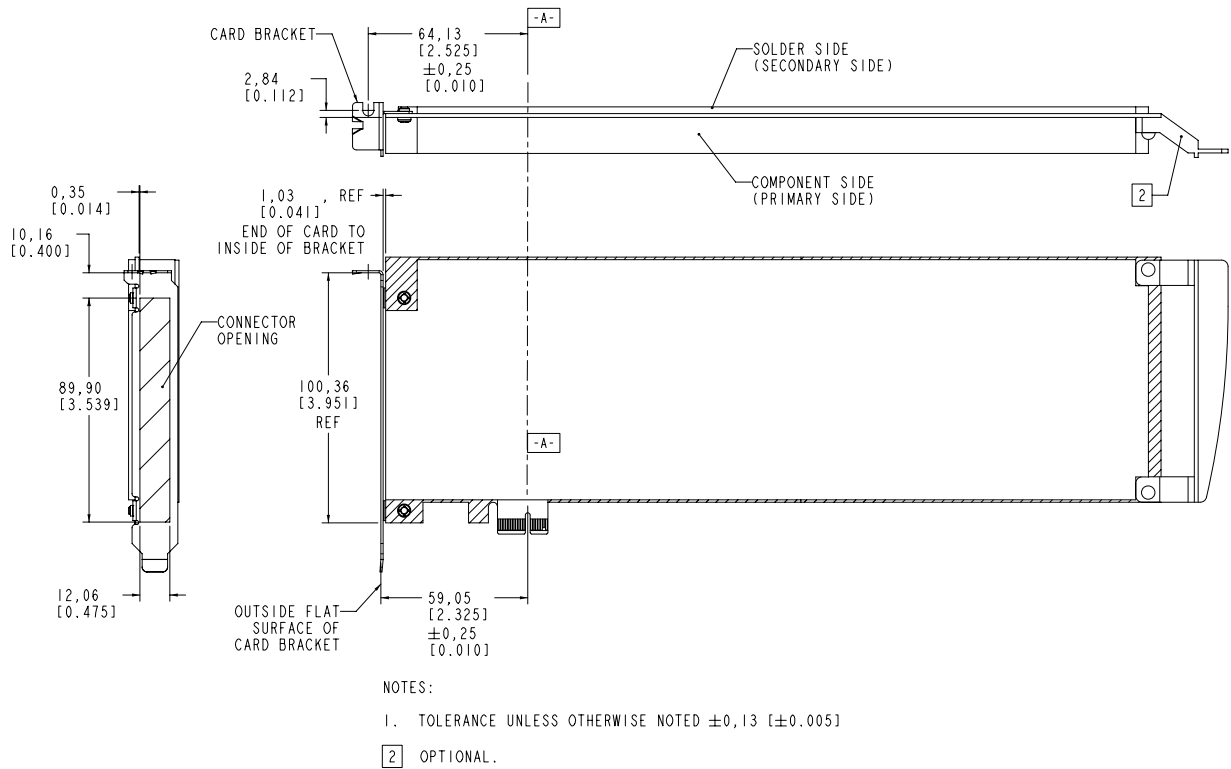

Figure 6-2: Standard Height PCI Express Add-in Card with the I/O Bracket and Card Retainer

The mounting holes illustrated in Figure 6-1 are required only on the right end of the full-length card (312.00 mm). Those holes are needed to install the optional PCI add-in card retainer, as illustrated in Figure 6-2.

5 The mounting holes and keep-out zones around them marked as note 3 in Figure 6-1 are required on those cards in which the I/O bracket is mounted to the card directly. The purpose of this keep-out is to ensure that the card cannot short out on the I/O bracket. On full-length cards, a keep-out of 5.08 mm is required to prevent card components from being damaged by the system's card guides (refer to Figure 6-1).

10 All graphics cards are required to be retention ready as defined in Section 5.2. This retention ready requirement may also apply to x1, x4, x8, or x16 I/O cards at each OEM, or add-in card manufacturer's discretion. See Section 5.2 for more information.

Special attention shall be given to graphics cards because of their potential high mass, driven by the high power allowed. This specification defines the additional feature and keepouts for x16 graphics cards for card retention shown in Figure 6-3.

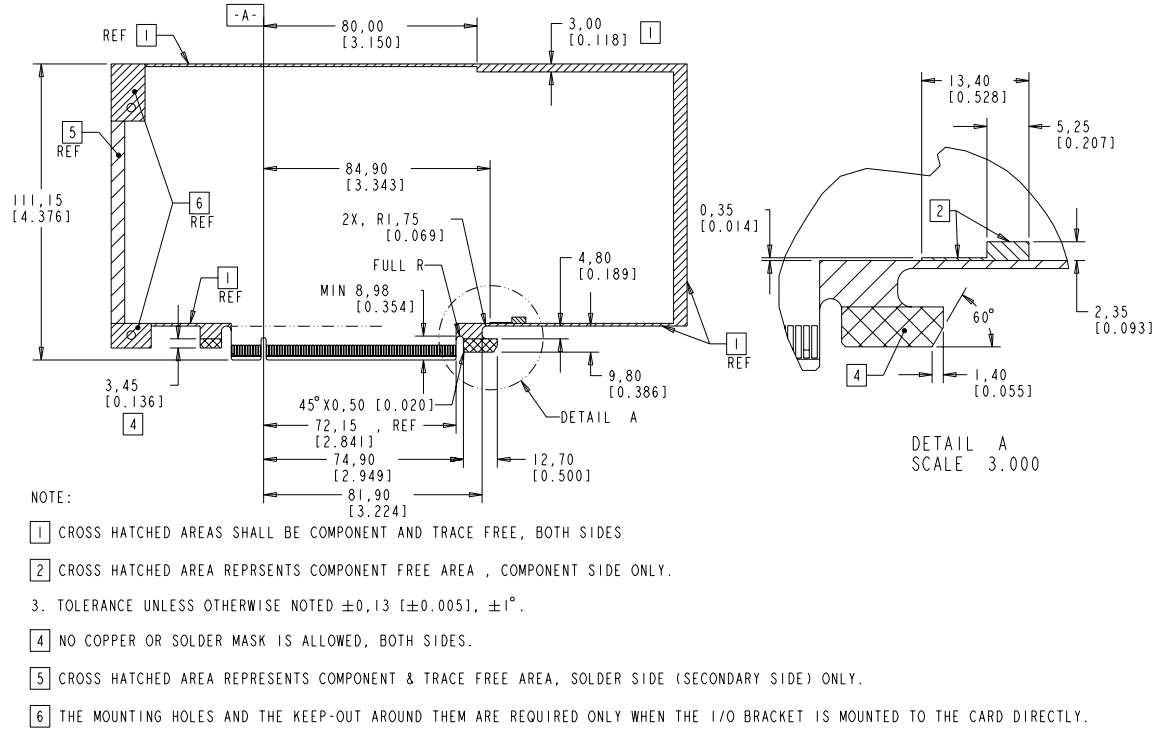

Figure 6-3: Additional Feature and Keepouts on the x16 Graphics Card

The 3.0-mm keepout on the top of the card is to accommodate system or chassis level card retention solutions at each OEM’s discretion. To facilitate a chassis level retention solution, the height of the standard height graphics card is required to be fixed: 111.15 mm ± 0.13 mm. Low profile graphics cards do not require the 3.00-mm keepout.

- 5 The “hockey stick” shaped feature and keepout defined on the bottom of the card is to allow retention mechanisms either mounted directly on the system board or integrated into the x16 connector. This feature and keepout are also required for the low profile graphics card.

All retention mechanisms that are intended for the x16 graphics cards must use the feature/keepout defined in Figure 6-3. But the specific retention mechanism design is system manufacturers’ choice.

- 10 Reference retention mechanism designs are given in the *PCI Express Graphics Card Thermal and Mechanical Design Guideline for Desktop Systems*.

Figure 6-4 shows the standard PCI Express I/O bracket, which is the same as the PCI bracket. The mounting tabs of the bracket shown in Figure 6-4 are to be mounted onto the secondary side of the card, as illustrated in Figure 6-2. However, a user also has the option to have a bracket with the mounting tabs mounted onto the primary side of the card, as depicted in Figure 6-5.

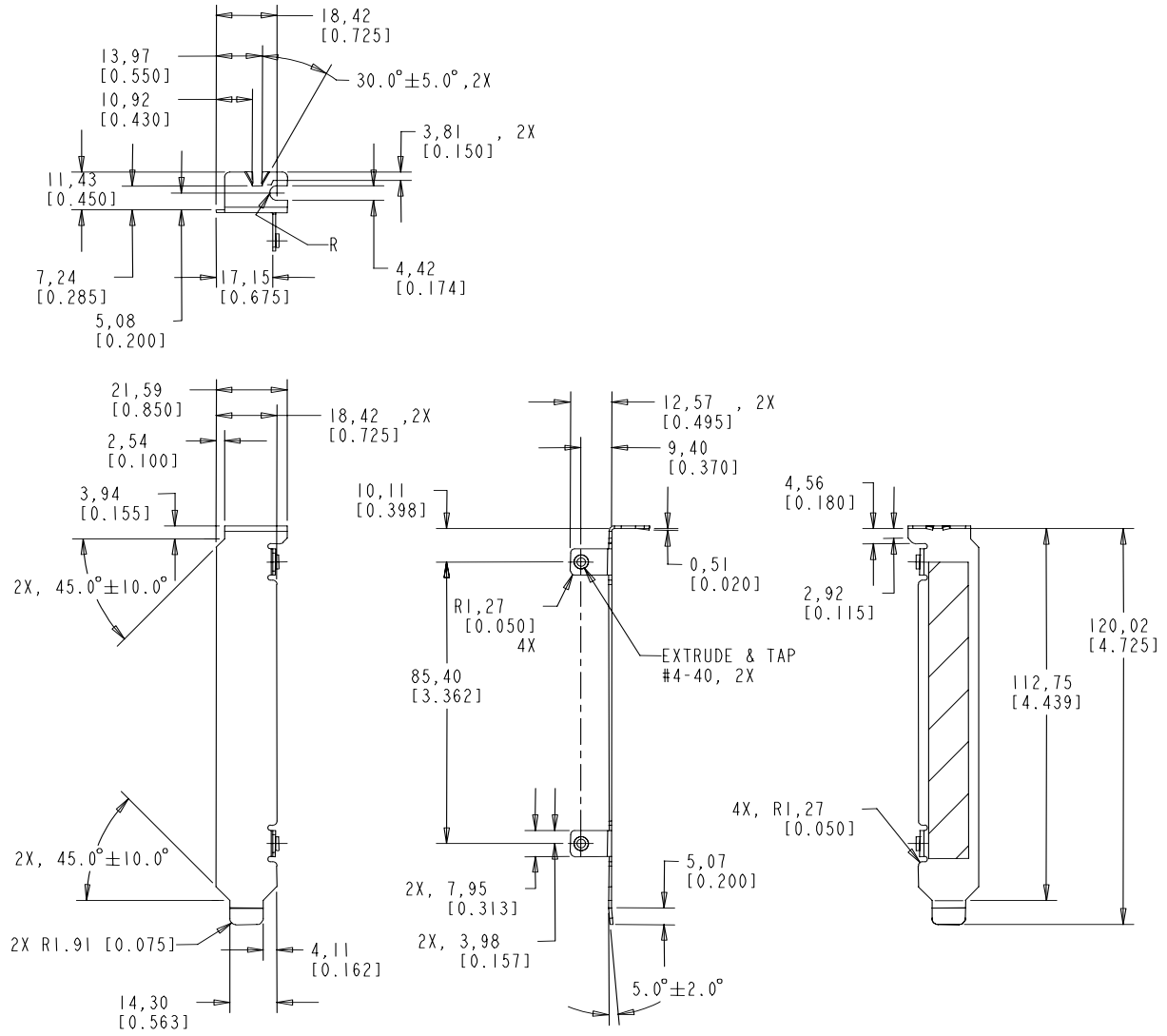

NOTES:

1. MATERIAL: 0.86MM [0.034 INCH] THICK (20 GA)
2. TOLERANCE UNLESS OTHERWISE NOTED ±0.27 [±0.010]

Figure 6-4: Standard Add-in Card I/O Bracket

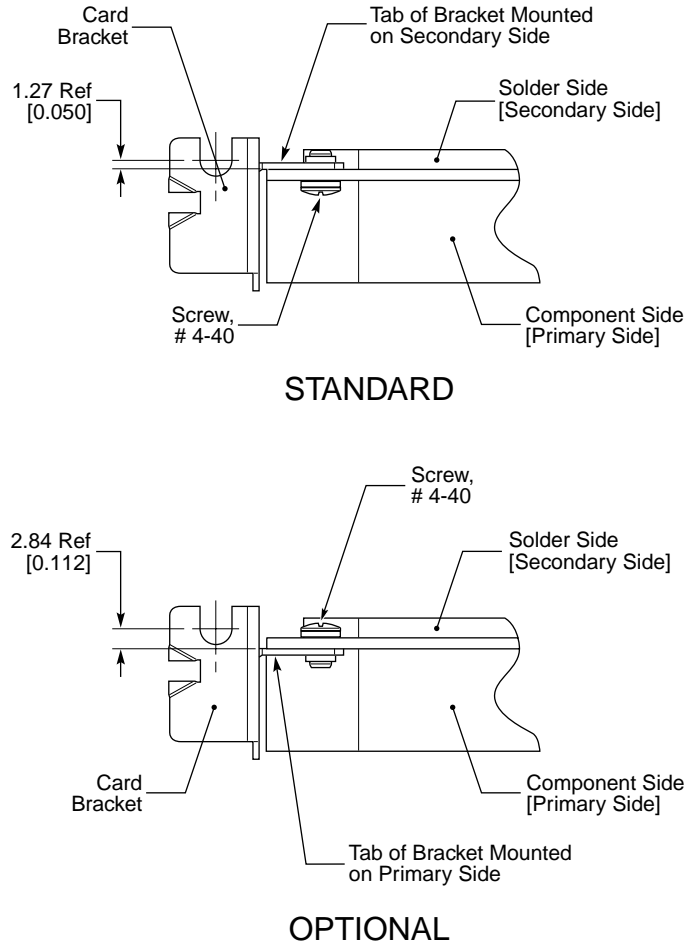

OM14763

Figure 6-5: Bracket Design with the Mounting Tabs Mounted on the Primary Side of the Add-in Card

The PCI Express add-in card retainer is the same as the PCI card retainer, an optional feature used only with the full-length add-in cards at the maximum length of 312.00 mm (12.283 inches). Figure 6-6 shows the PCI Express add-in card retainer dimensions.

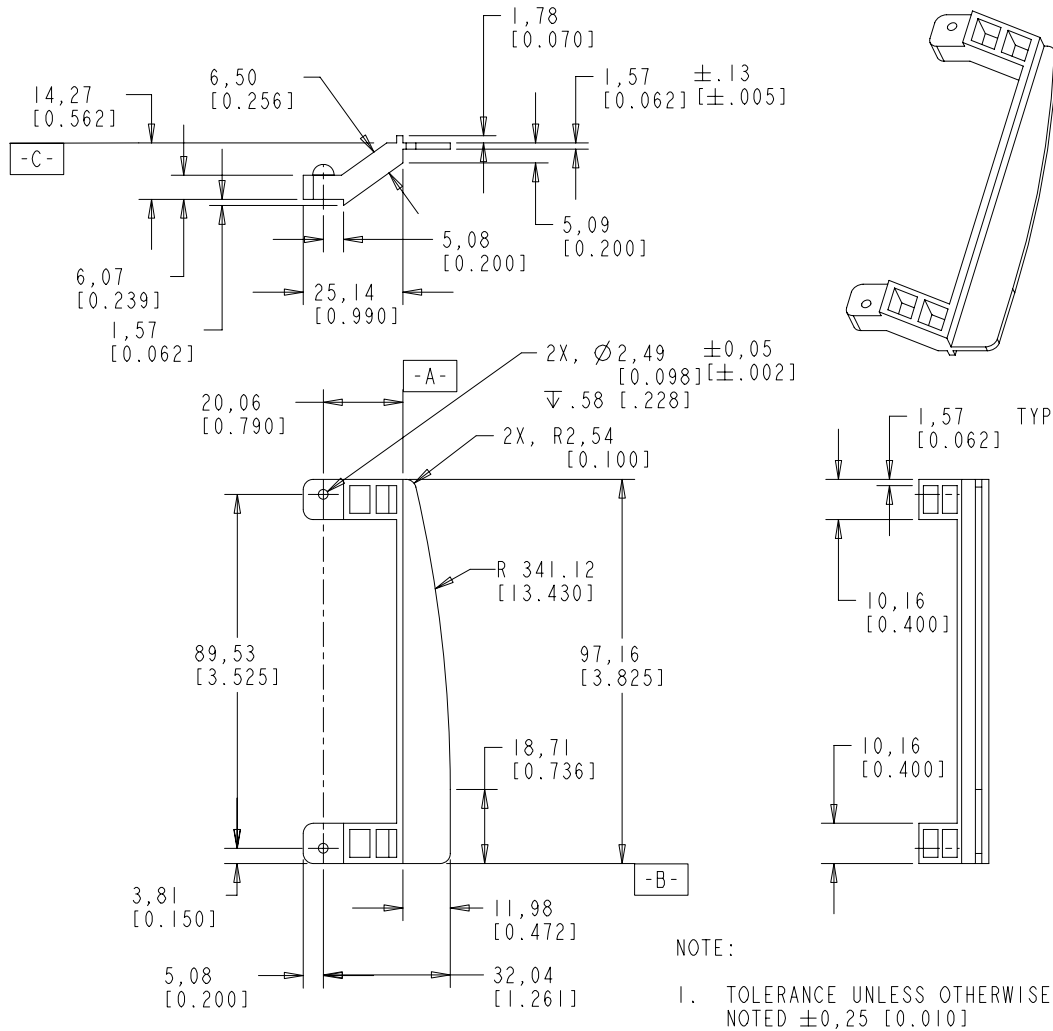
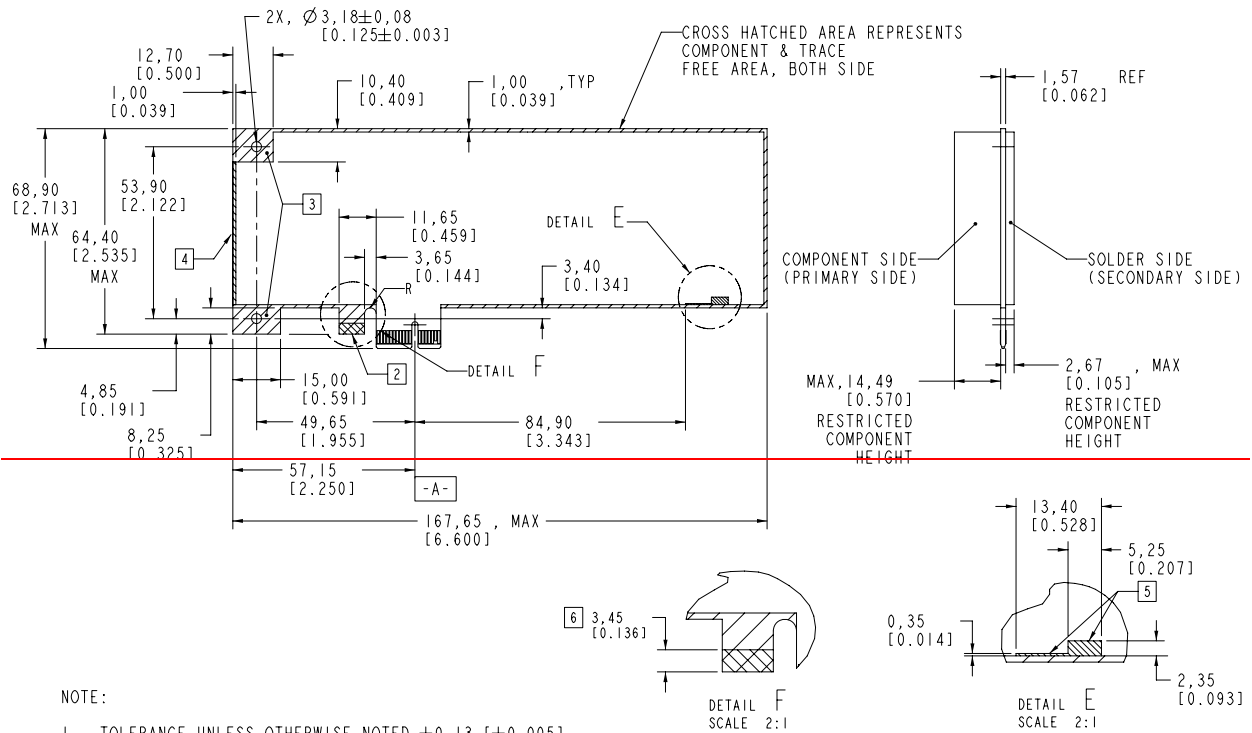

Figure 6-6: Add-in Card Retainer

The detailed add-in card edge finger dimensions are defined in Section 5.2, which describes the connector mating interface. The edge-finger portions of the PCI Express cards are required to have bevels or chamfers as defined in Figure 5-3.

Figure 6-7 and Figure 6-8 show, respectively, the low profile PCI Express add-in card form factor without and with the bracket, while Figure 6-9 shows the low profile add-in card I/O bracket. When mounting a low profile card into a full height PCI slot, the standard I/O bracket must be modified to add a stiffening flange. Figure 6-10 shows the modified full height I/O bracket for low profile cards.

5



NOTE:

1. TOLERANCE UNLESS OTHERWISE NOTED $\pm 0,13$ [± 0.005]

2 THIS FEATURE IS TO PREVENT THE PCI EXPRESS CARD FROM BEING PLUGGED INTO PCI CONNECTORS.

3 THE MOUNTING HOLES AND THE KEEP-OUT AROUND THEM ARE REQUIRED ONLY WHEN THE I/O BRACKET IS MOUNTED TO THE CARD DIRECTLY.

4 CROSS HATCHED AREA REPRESENT COMPONENT & TRACE FREE AREA, SOLDER SIDE (SECONDARY SIDE) ONLY.

5 CROSS HATCHED AREA REPRESENTS COMPONENT FREE AREA, COMPONENT SIDE ONLY.

6 NO COPPER OR SOLDER MASK IS ALLOWED, BOTH SIDE.

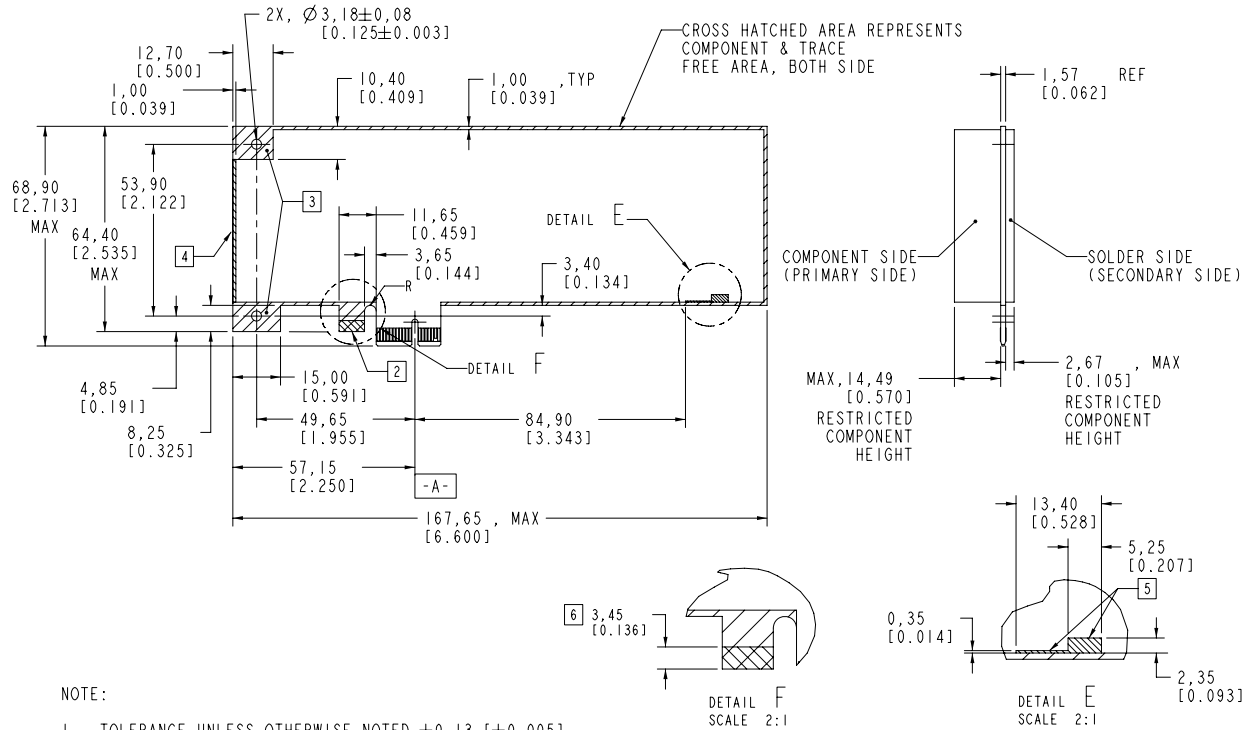
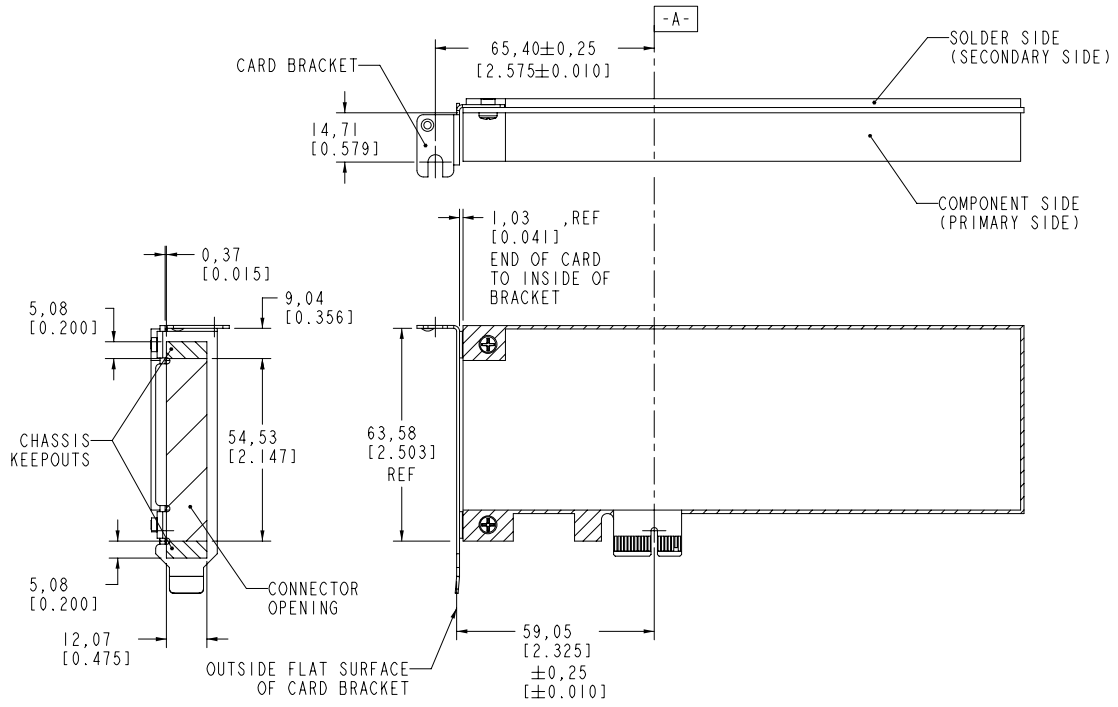

Figure 6-7: Low Profile PCI Express Add-in Card without the I/O Bracket



NOTES:

1. TOLERANCE UNLESS OTHERWISE NOTED $\pm 0,13$ [± 0.005]

Figure 6-8: Low Profile PCI Express Add-in Card with the I/O Bracket

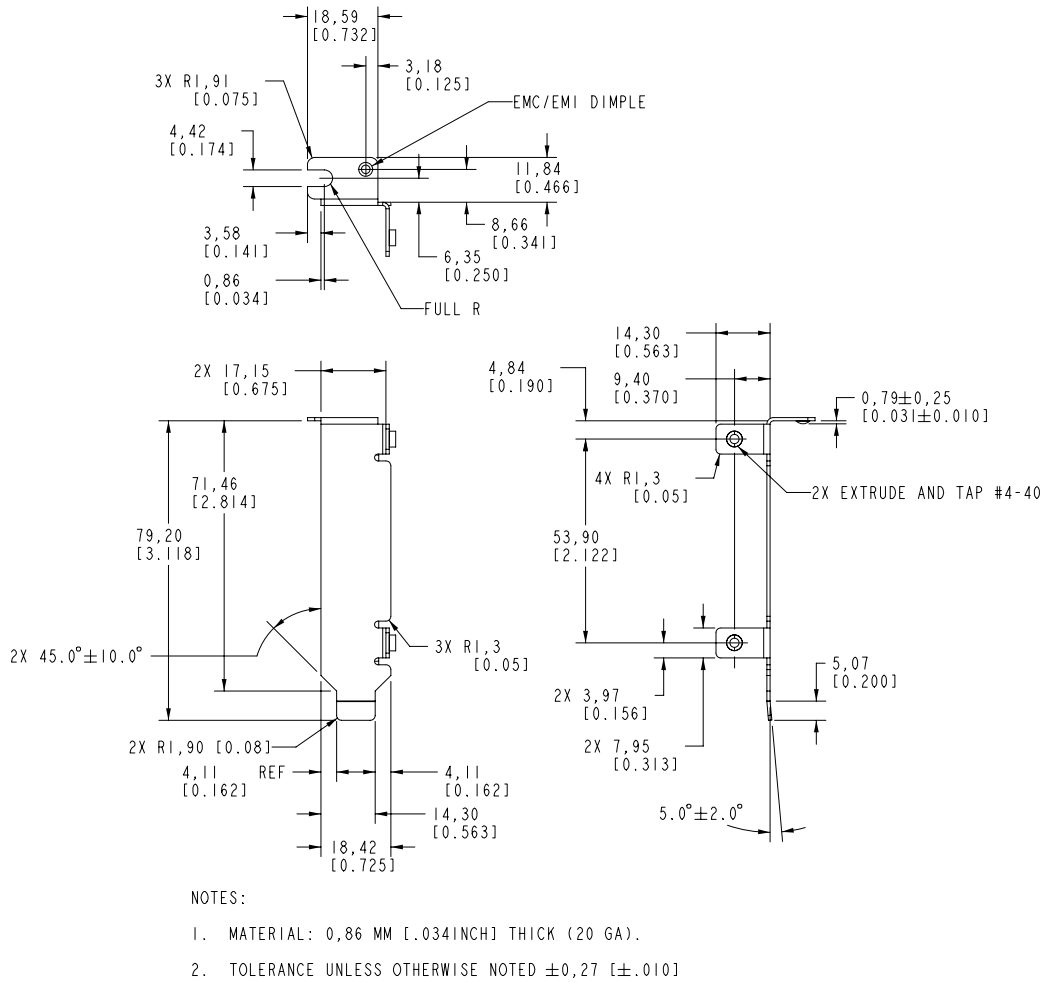
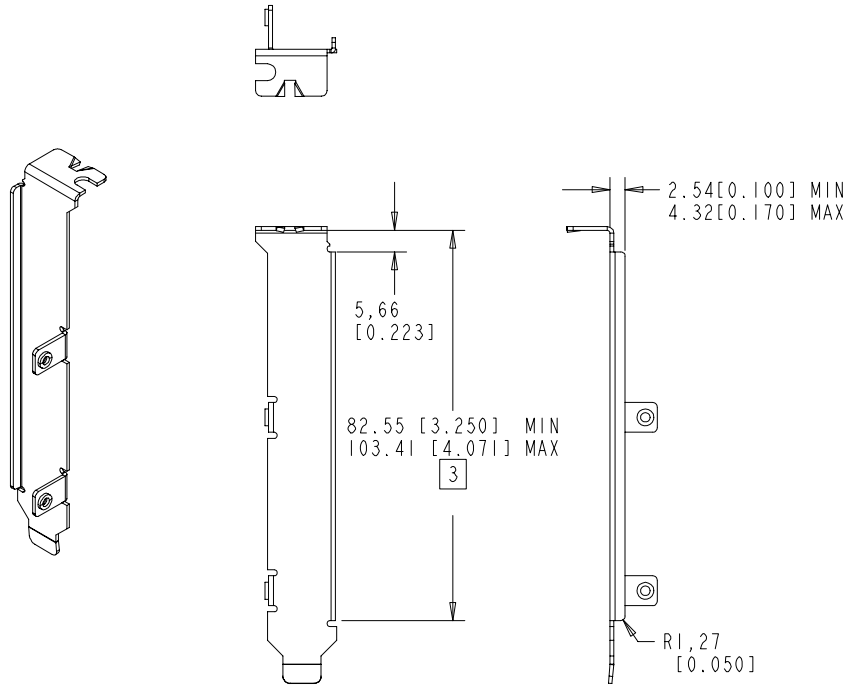

Figure 6-9: Low Profile I/O Bracket



NOTES:

1. STIFFENING FLANGE IS REQUIRED WHEN MOUNTING A LOW PROFILE CARD TO A FULL HEIGHT BRACKET
2. STIFFENING FLANGE IS OPTIONAL WHEN MOUNTING A FULL HEIGHT CARD
- 3 THIS DIMENSION PROVIDES FOR CLEARANCE BETWEEN THE FLANGE AND COMPONENTS ON THE MOTHER BOARD.
4. THIS DRAWING SHOWS THE DIMENSIONS OF THE STIFFENING FLANGE ONLY. SEE FIGURE 6-4 FOR DIMENSIONS OF THE REMAINING FEATURES
5. TOLERANCE UNLESS OTHERWISE NOTED $\pm 0,25$ [± 0.010]

Figure 6-10: Full Height I/O Bracket for Low Profile Cards

6.2. Connector and Add-in Card Locations

Figure 6-11 shows an example of a typical desktop system (microATX form factor). The add-in card slots are occupied by the PCI and AGP add-in card connectors.

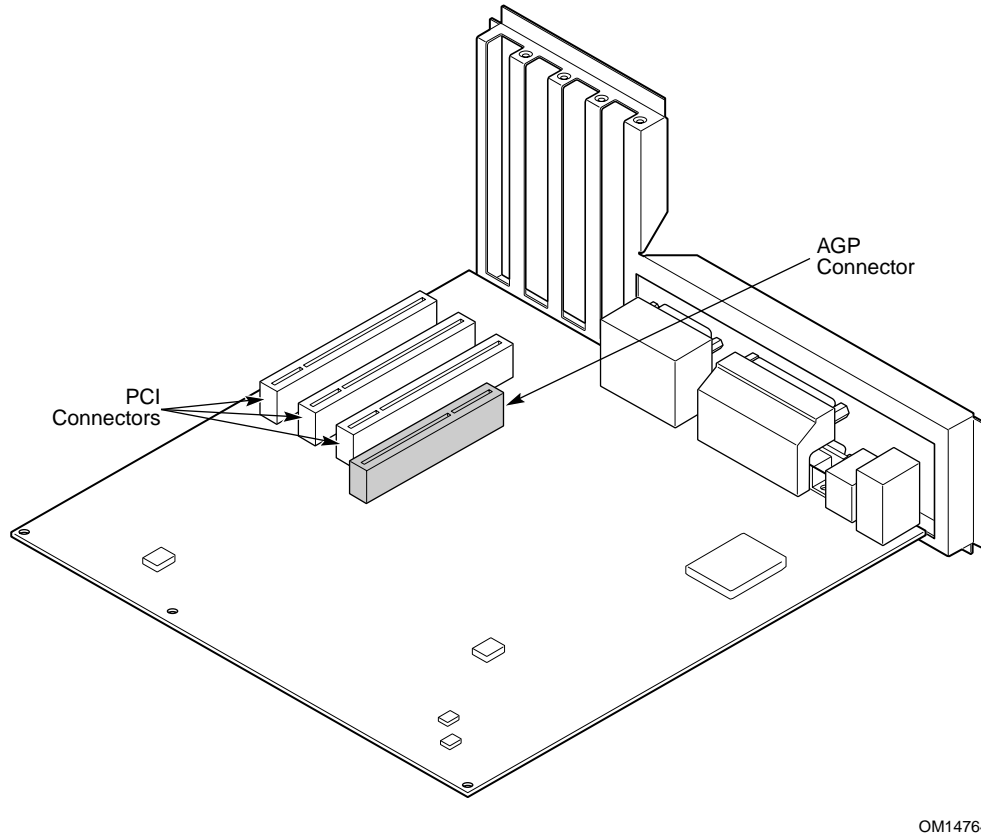

OM14764

Figure 6-11: Example of a PC System in microATX Form Factor

The PCI Express add-in cards will use the space allocated for those add-in card slots to take advantage of the existing chassis infrastructure. This requirement dictates that the PCI Express connectors must use the slots that coincide with the locations of the present PCI and AGP slots/connectors.

Figure 6-12 illustrates the introduction of a PCI Express connector in a microATX system, co-existing with the PCI connectors. In this case, the PCI Express connector is introduced by replacing the AGP connector.

Like the PCI add-in card, the components on a PCI Express add-in card face away from the CPU, or the core area.

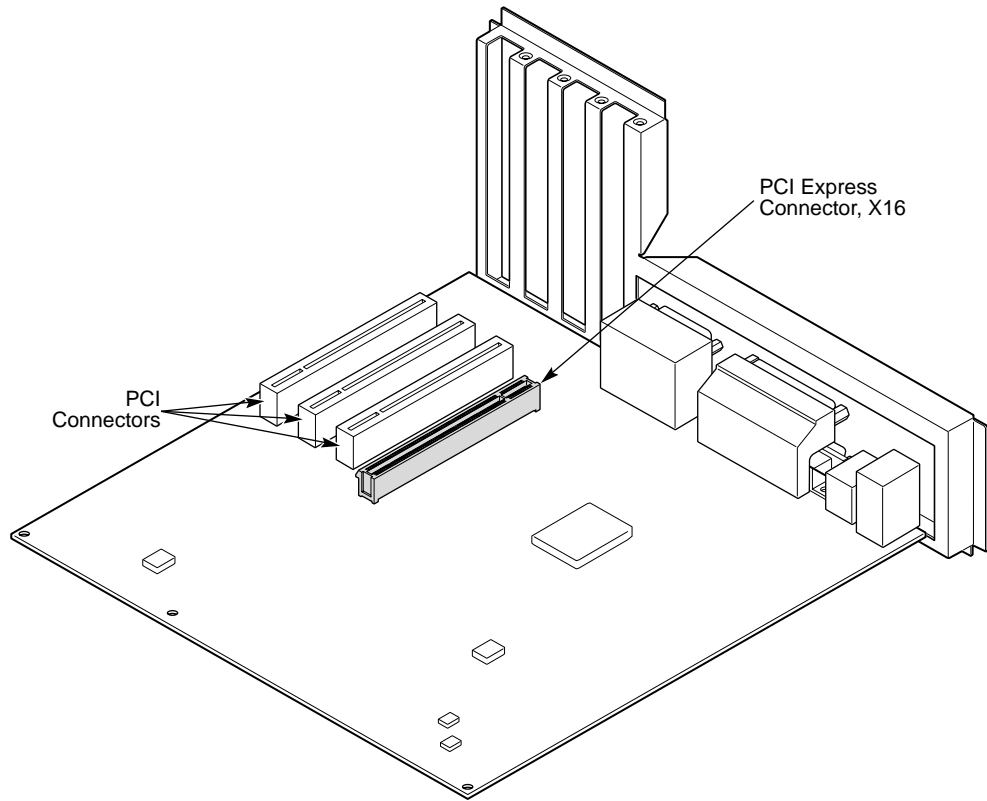

OM14765

Figure 6-12: Introduction of a PCI Express Connector in a microATX System

Over time, more PCI Express connectors will be used on the system board. Figure 6-13 shows a situation in which a basic bandwidth PCI Express connector replaces a PCI connector (x1) and a high bandwidth (x16) PCI Express connector replaces the AGP connector.

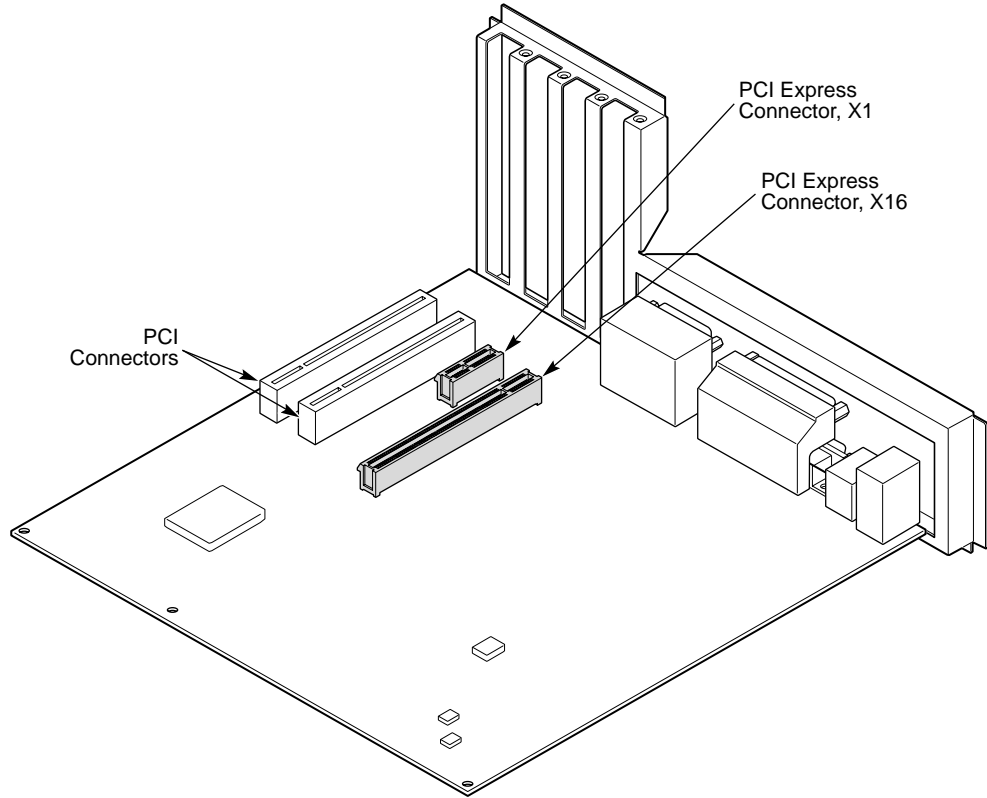

OM14766

Figure 6-13: More PCI Express Connectors are Introduced on a microATX System Board

Figure 6-15 shows the PCI Express connector location, as well as the component height restriction zones. In this case, a x16 PCI Express connector replaces the AGP connector. When more PCI Express connectors are introduced, the height restriction zones will grow accordingly. This is depicted in Figure 6-16, where an additional x1 PCI Express connector is introduced along with the x16 connector. The 5.08 mm (0.200 inches) maximum and the 15.24 mm (0.600 inches) maximum height restriction zones are identical to the PCI requirements. But the additional, small height restriction zones of 6.35 mm (0.250 inches) max are unique to PCI Express.

There is a slight offset between PCI and PCI Express connector locations. The PCI Express connectors are located slightly further away from the rear of the chassis. The PCI Express add-in cards contain features (see Note 2 in Figure 6-1 and Figure 6-7) to prevent them from being mistakenly inserted into a PCI slot. Such features require the additional height restriction zones of 6.35 mm (0.250 inches) maximum.

The card retention clip may require additional height restrictions. Such restrictions depend on the retention clip design and location, which may vary from user to user. Thus, they are not specified here as a requirement. However, in the design guideline, a reference retention clip design and implementation is given, together with the keep-out and height restriction zones.

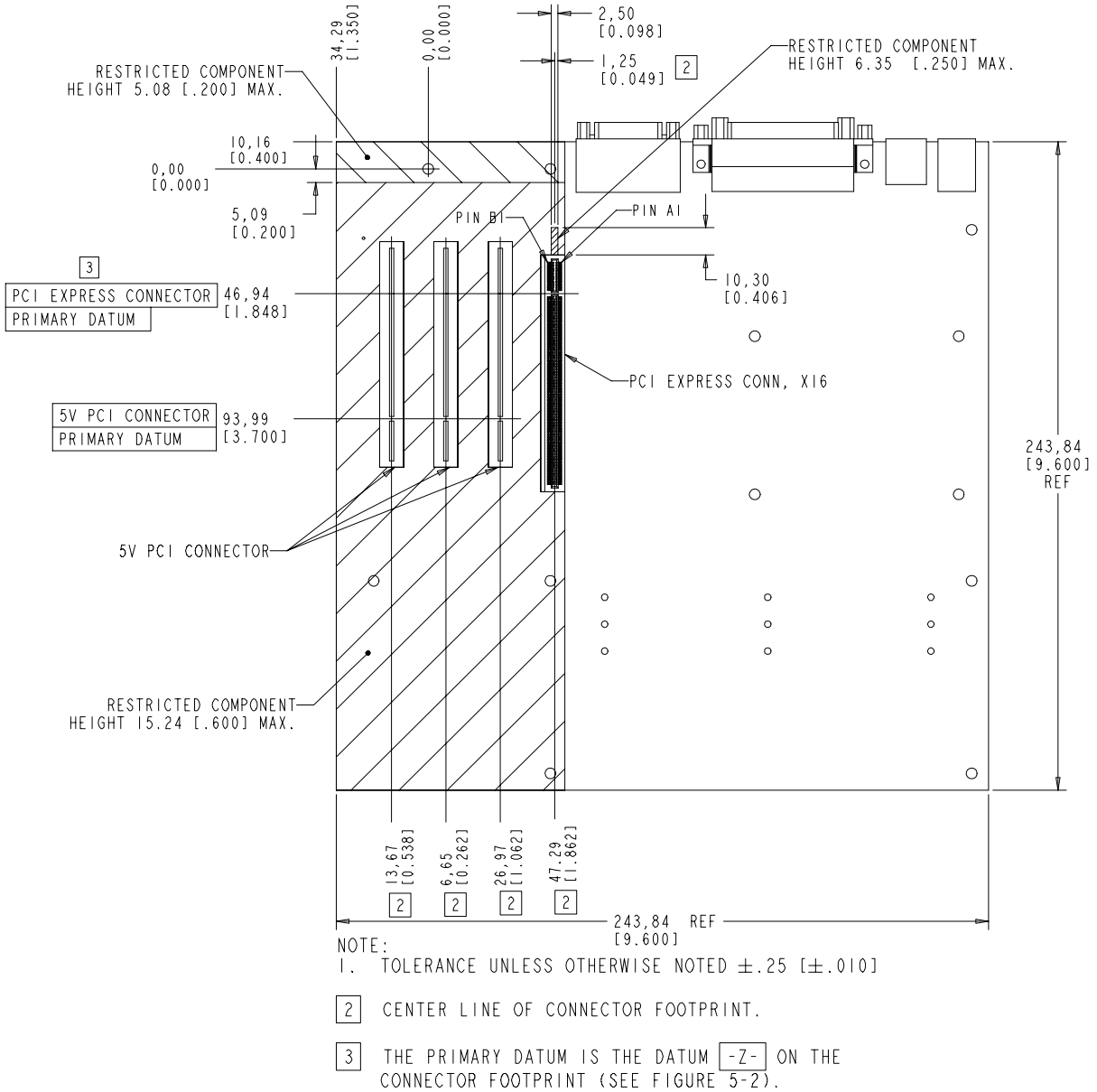

Figure 6-13: ~~PCI Express Connector Location in a microATX System with One PCI Express Connector~~

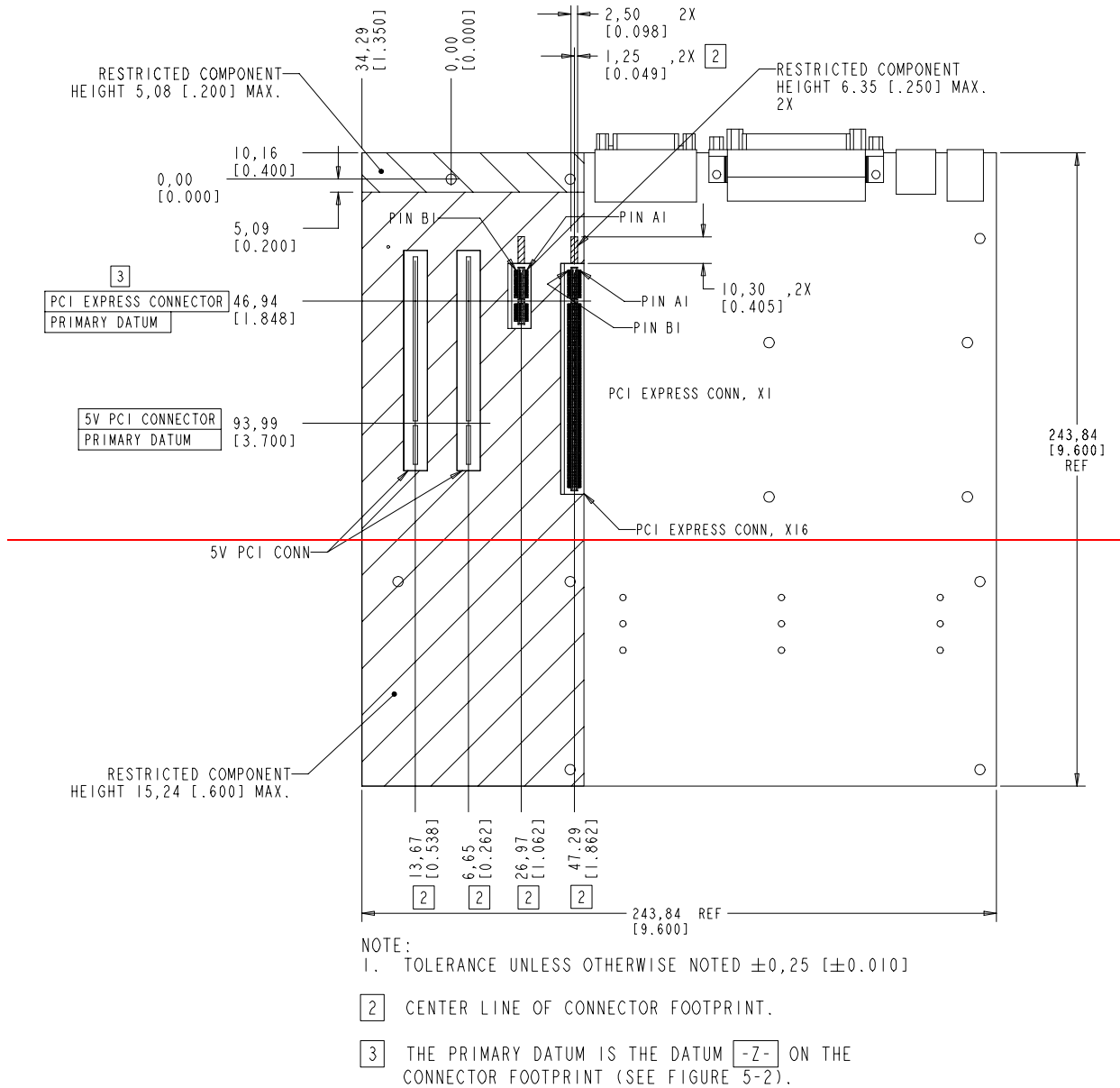
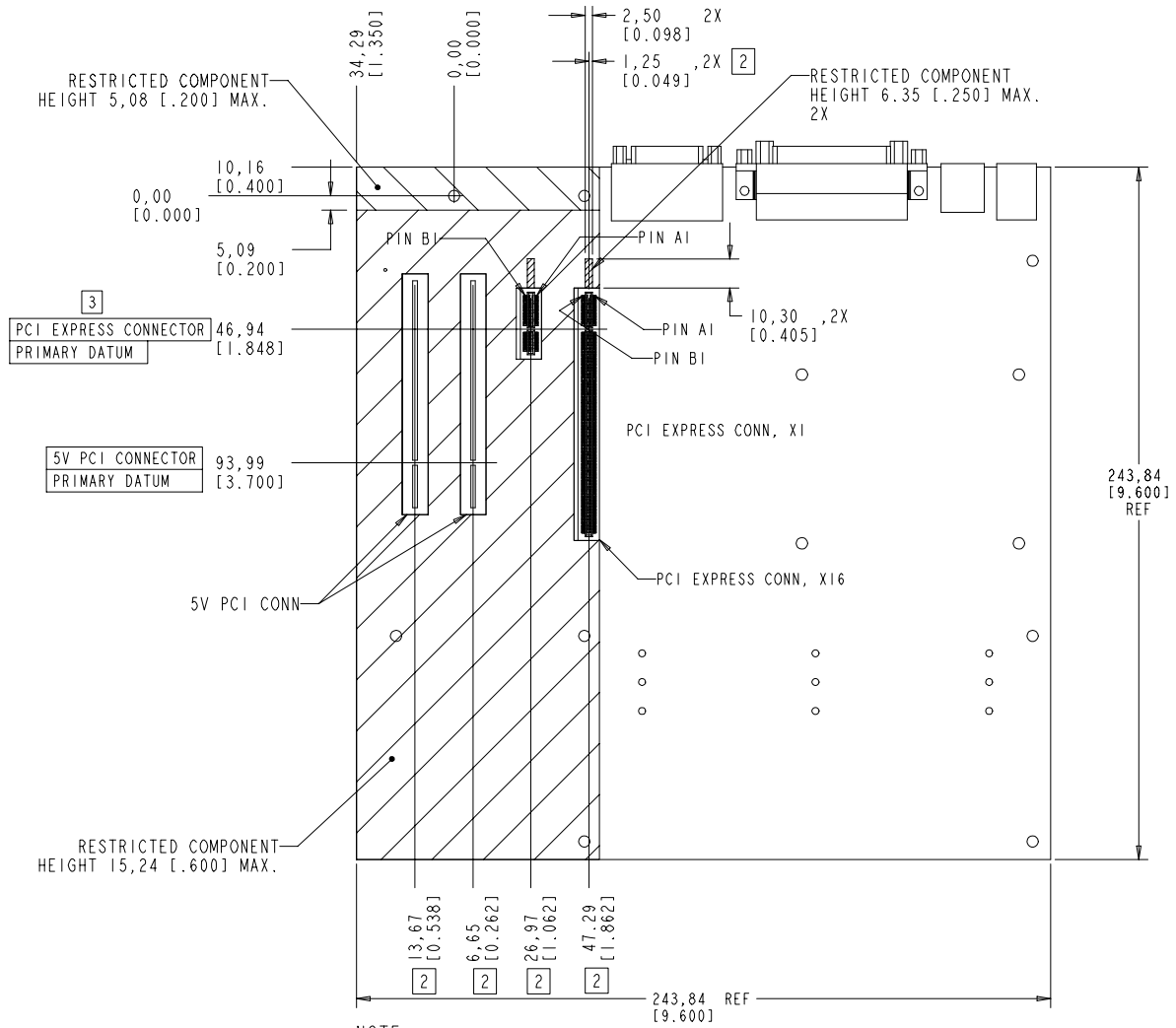

Figure 6-15: PCI Express Connector Location in a microATX System with One PCI Express Connector



NOTE:
1. TOLERANCE UNLESS OTHERWISE NOTED $\pm 0,25$ [± 0.010]

[2] CENTER LINE OF CONNECTOR FOOTPRINT.

[3] THE PRIMARY DATUM IS THE DATUM [-Z-] ON THE CONNECTOR FOOTPRINT (SEE FIGURE 5-2).

Figure 6-16: PCI Express Connector Location in a microATX System with Two PCI Express Connectors

Figure 6-17 shows the card height with respect to the top surface of the system board when assembled into a connector.

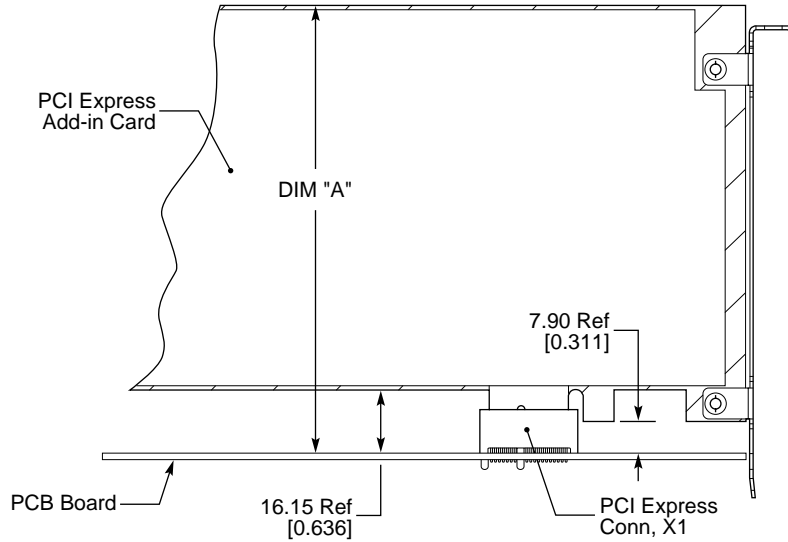

DIM "A"	
STANDARD HEIGHT	114.55 [4.510] MAX.
LOW PROFILE	72.30 [2.846] MAX.

OM14767

Figure 6-17: Card Assembled in Connector

6.3. Card Interoperability

PCI Express cards and ~~slots~~ connectors exist with a variety of Link widths. The interoperability of cards and ~~slots~~ connectors is summarized in Table 6-2.

Table 6-2: Card Interoperability

Slot <u>Connector</u> _ Card	x1	x4 <u>X4</u>	x8 <u>X8</u>	x16
x1	Required	Required	Required	Required
x4	No	Required	Allowed <u>Required</u>	Allowed <u>Required</u>
x8	No	No	Required	Allowed <u>Required</u>
x16	No	No	No	Required

Note that the [connectors here refer to the receptacle connectors mounted on a system board, as defined in Chapter 5](#). The shaded area above the diagonal of Table 6-2 represents up-plugging, while the area below the diagonal represents down-plugging. The following points should be noted:

- 5 ❑ Down-plugging, i.e., plugging a larger ~~Link~~-edge size card into a smaller ~~Link~~-connector, is not allowed and is physically prevented.
- 10 ❑ Up-plugging, i.e., plugging a smaller ~~Link~~-edge size card into a larger ~~Link~~-connector, is ~~fully allowed~~-supported.
- 10 ❑ ~~Down-shifting, which is defined as plugging a PCI Express card into a connector that is not fully routed for all of the PCI Express lanes, in general is not allowed. The exception is the x8 connector which the system designer may choose to route only the first four PCI Express lanes.~~ [All PCI Express add-in cards must be able to negotiate and operate in all smaller Link widths from the full Link width down to x1. The x2 and x12 Link widths are optional.](#)
- 15 ❑ [The upstream PCI Express components on a system board must be able to negotiate and operate in all smaller Link widths from the full Link width down to x1. The x2 and x12 Link widths are optional.](#)

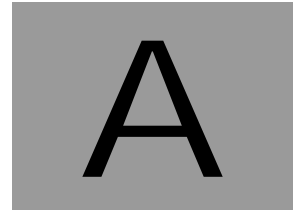

A. Insertion Loss Values (Voltage Transfer Function) (Informational Only)

The maximum loss values in dB (decibels) are specified for the system board and the add-in card. The insertion loss values are defined as the ratio of the voltage at the ASIC package pin (Transmitter/Receiver) and the voltage at the PCI Express connector interface, terminated by 100 Ω differential termination, realized as two 50 Ω resistances. These resistances are referenced to ground at the interface (see Figure A-1).

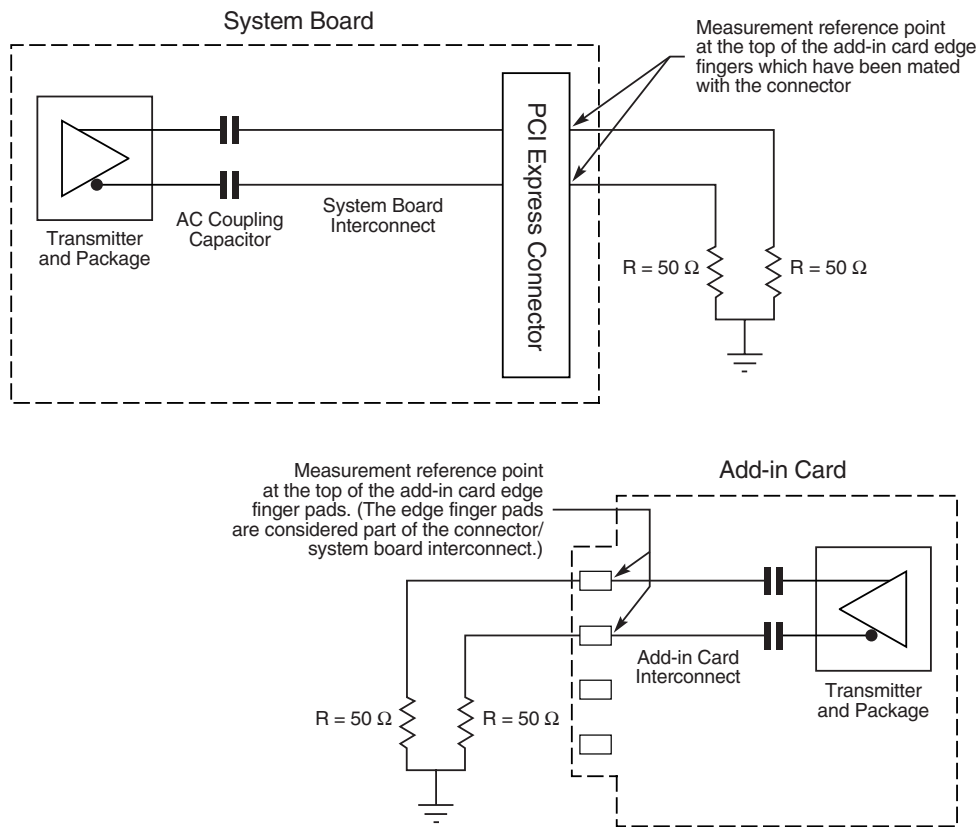

A-0337

Figure A-1: Example Interconnect Terminated at the Connector Interface

All PCI Express differential trace pairs are required to be referenced to the ground plane. The loss values associated with any riser card interface and adjoining connector implementation must collectively meet the system board loss budget allocations and associated eye diagrams.

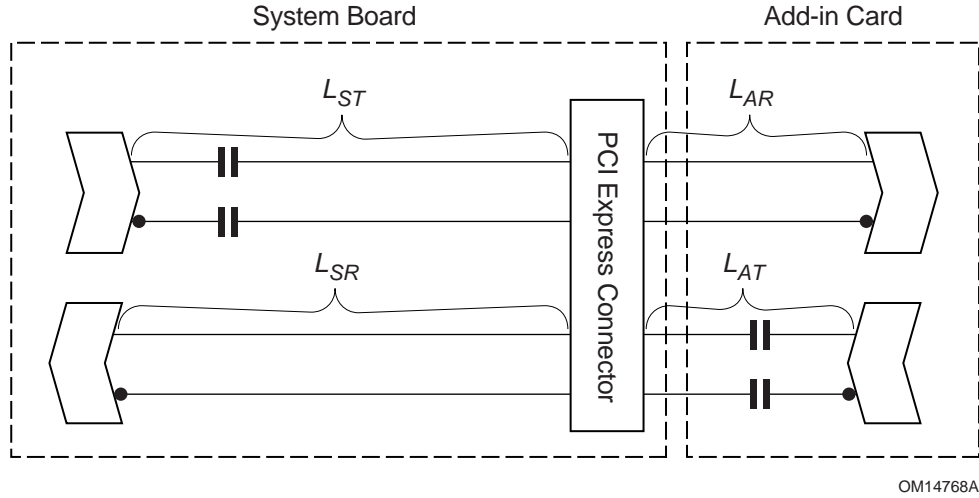

Figure A-2: Insertion Loss Budgets

Table A-1: Allocation of Interconnect Path Insertion Loss Budget For 2.5 GT/s Signaling

Loss Parameter	Loss Budget Value at 1.25 GHz (dB)		Loss Budget Value at 625 MHz (dB)		Comments
	L_{AR}	L_{AT}	L_{AR}	L_{AT}	
PCI Express Add-in Card	$L_{AR} < 2.65$	$L_{AT} < 3.84$	$L_{AR} < 1.95$	$L_{AT} < 2.94$	Notes 1, 2
System Board and Connector	$L_{ST} < 9.30$	$L_{SR} < 8.11$	$L_{ST} < 6.00$	$L_{SR} < 5.01$	Notes 1, 3
Guard Band	1.25		1.25		Note 1
Total Loss	$L_T < 13.2$		$L_T < 9.2$		

Notes:

- All values are referenced to 100 Ω , realized as two 50 Ω resistances. The loss budget values include all possible crosstalk impacts (near-end and far-end) and potential mismatch of the actual interconnect with respect to the 100 Ω reference load.

The PCI Express Base Specification, Revision 2.0 allows an interconnect loss of 13.2 dB for 1.25 GHz (non de-emphasized) signals and 9.2 dB for 625 MHz (de-emphasized) signals. From this, a total of 1.25 dB is held in reserve as guard band to allow for any additional attenuation that might occur when the add-in card and system board are actually mated. The allocated loss budget values in the table directly correlate to the eye diagram voltages in Section 4.7. Tradeoffs in terms of attenuation, crosstalk, and mismatch can be made within the budget allocations specified.

As a guide for design and simulation, the following derivation of the budgets may be assumed for 1.25 GHz signals: 5.2 dB is subtracted from 13.2 dB to account for near-end crosstalk and impedance mismatches. Out of this, the 1.25 dB is reserved as guard band. The following loss allocations are then assumed per differential pair: $L_{AR} = 1.4$ dB; $L_{AT} = 1.8$ dB; $L_{SR} = 6.2$ dB; $L_{ST} = 6.6$ dB. These allocation assumptions must also include any effects of far-end crosstalk. 625 MHz values may be derived in a similar manner.

- 5
2. The add-in card budget does not include the add-in card edge finger or connector. However, it does include potential AC coupling capacitor attenuation on the Transmitter (TX) interconnect on add-in card. Note that the budget allocations generally allow for a maximum of 4-inch trace lengths for differential pairs having an approximate 5-mil trace width. No specific trace geometry, however, is explicitly defined in this specification. The subscripts of the symbol designators, T and R, represent the Transmitter and Receiver respectively.
 - 10 3. The system board budget includes the PCI Express connector and assumes it is mated with the card edge finger. Refer to Section 5.3 for specifics on the standalone connector budget. The system board budget includes potential AC coupling capacitor attenuation on the Transmitter (TX) interconnect on the system board. The subscripts of the symbol designators, T and R, represent the Transmitter and Receiver respectively.

15 Note: The insertion loss budget distributions above are used to derive the eye diagram heights as described in Section 4.7. However, they are provided here only as a design guideline. Compliance measurements must actually be verified against the eye diagrams themselves as defined in Section 4.7.

20 The *PCI Express Base Specification, Revision 2.0* provides design guidelines for channels designed to support 5 GT/s signaling.

Acknowledgements

The following persons were instrumental in the development of the PCI Express Card Electromechanical Specification:⁶

Richard Allrot	Hewlett-Packard Company	Dave Moss	Dell Inc Computer Corporation
Bob Atkinson	Tyco International, Ltd.	Scott Noble	Intel Corporation
Ed Boeckmann	3Dlabs, Inc. Ltd.	Ta-Wee Ong	Molex Incorporated
Jim Brewer	Dell Computer Corporation Inc	John Pescatore	Dell Inc Computer Corporation
James Bullington	3Dlabs, Inc. Ltd.	Curt Progl	Dell Inc Computer Corporation
Raymond Chin	Hewlett-Packard Company	Eddie Reid	Intel Corporation
Michael Cheong	Molex Incorporated	Martha Rupert	FCI
KengYin Chok	Molex Incorporated	Rodrigo Samper	IBM Corporation
Dr. Jason Chou	Foxconn Electronics, Inc.	Bill Sauber	Dell Inc Computer Corporation
Don Craven	Intel Corporation	Rick Schuckle	Dell Inc Computer Corporation
Dave Davitian	Tyco International, Ltd.	Joe Sekel	Dell Inc Computer Corporation
Bassam Elkhoury	Intel Corporation	Joanne E. Shipe	Foxconn Electronics, Inc.
Ikuo Enomoto	Tyco International, Ltd.	Dave Sideck	FCI
David Farmer	3Dlabs, Inc. Ltd.	Chuck Stancil	Hewlett-Packard Company
Don Faw	Intel Corporation	John Stuewe	Dell Inc Computer Corporation
George Hayek	Intel Corporation	Tom Sultzer	FCI
Dave Helster	Tyco International, Ltd.	Toru Tamaki	Tyco International, Ltd.
Ted Holden	Intel Corporation	Junichi Tanigawa	Tyco International, Ltd.
Carl Jackson	Hewlett-Packard Company	Clay Terry	3Dlabs, Inc. Ltd.
Mike Krause	Hewlett-Packard Company	SY Theng	Molex Incorporated
Doron Lapidot	Tyco International, Ltd.	Alok Tripathi	Intel Corporation
Cliff Lee	Intel Corporation	Andy Vasbinder	FCI
PT Lim	Molex Incorporated	Gary Verdun	Dell Inc Computer Corporation
Yun Ling	Intel Corporation	Andy Volk	Intel Corporation
Howard Locker	IBM Corporation	Chris Womack	Hewlett-Packard Company
Alan MacDougall	Molex Incorporated	Mike Woren	Tyco International, Ltd.
Bob Marshall	FCI	Yoshisha Yamamoto	Tyco International, Ltd.
Mike Miller	IBM Corporation	Dave Zenz	Dell Inc Computer Corporation
Dan Froelich	Intel Corporation	Mike Li	Wavecrest Corporation
Jason Bradley	Intel Corporation	Clint Walker	Intel Corporation
Justin Coppin	Hewlett-Packard Company	Nima Osqueizadeh	ATI Technologies, Ltd.

⁶ Company affiliation listed is at the time of specification contributions.

Juli Olenick	Tyco International, Ltd.	Steve Millard	Tyco International, Ltd.
Jason Squire	Molex Incorporated	Christian Yameogo	Molex Incorporated
Jun Cao	Molex Incorporated	Ajay Kwatra	Dell Inc
Bob Hrehor	Dell Inc	Tom Lanzoni	Dell Inc
Scot Baumgartner	IBM Corporation	Karl Dittus	IBM Corporation
Robert Elliot	Hewlett-Packard Company	Dr David Quint	Hewlett-Packard Company
A. J. Yang	Foxconn Electronics, Inc.	Jim Koser	Foxconn Electronics, Inc.
Stefaan Sercu	FCI	Ozgur Toprakli	FCI
Nathan Altland	FCI	Richard Chiu	FCI
Wil de Bont	National Instruments Corporation	Gold Mao	Via Technologies, Inc.